



R-410A Ducted Horizontal Air Conditioner

ENVIRONMENTALLY SOUND R-410A REFRIGERANT

1-1/2 THRU 5 TONS, 208/230 Volt, 1-Phase

3 THRU 5 TONS, 208/230 Volt, 3-Phase

3 THRU 5 TONS, 460 Volt, 3-Phase

Energy Efficiency

- 13 – 14.5 SEER/11 – 12 EER

Sound

- Levels as low as 70 dBA

Design Features

- Matched with ducted indoor units
- Ideal for multi-family use
- Small footprint “stackable”
- Weather-resistant cabinet
 - All steel cabinet construction
 - Baked on powder paint
 - Mesh coil guard

Reliability, Quality and Toughness

- Scroll compressor
- Factory-supplied filter drier
- Factory installed Crankcase Heater on 2-1/2 through 5 ton models
- High pressure switch
- Line lengths up to 200 feet (61m) (see Long Line Application Guideline)
- 65 foot (20m) lift (see Long Line Application Guideline)
- Low ambient operation (down to -20°F/-28.9°C) with low ambient accessories
- Installation as close as 6 inches (152mm) from wall

Warranty*

Residential

- 5 year compressor limited warranty
- 5 year parts limited warranty (including compressor and coil)
 - With timely registration, an additional 5 year parts limited warranty (including compressor and coil)

* Applies to original purchaser/homeowner, some limitations may apply. See Warranty certificate for complete details.



This product has been designed and manufactured to meet ENERGY STAR criteria for energy efficiency when matched with appropriate coil components. However, proper refrigerant charge and proper air flow are critical to achieve rated capacity and efficiency. Installation of this product should follow the manufacturer's refrigerant charging and air flow instructions. Failure to confirm proper charge and airflow may reduce energy efficiency and shorten equipment life.



Use of the AHRI Certified TM Mark indicates a manufacturer's participation in the program. For verification of certification for individual products, go to www.ahridirectory.org.



Model Number	Voltage	Size (tons)	Nominal Btu/hr	Operating Weight lbs (kg)
HC4A318AKA	208/230	1-1/2	18,000	155 (70)
HC4A324AKA		2	24,000	180 (82)
HC4A330AKA		2-1/2	30,000	200 (91)
HC4A336AKA		3	36,000	218 (99)
HC4A348AKA		4	48,000	284 (129)
HC4A360AKA		5	60,000	294 (134)
3-Phase				
HC4A336AHA	208/230	3	36,000	218 (99)
HC4A336ALA	460			
HC4A348AHA	208/230	4	48,000	284 (129)
HC4A348ALA	460			
HC4A360AHA	208/230	5	60,000	294 (134)
HC4A360ALA	460			

Specifications subject to change without notice.

OUTDOOR UNIT MODEL NUMBER IDENTIFICATION GUIDE												
Digit Position:	1,2	3	4	5	6,7	8	9	10	11	12	13	
Example Part Number:	HC	4	A	3	18	A	K	A	1	0	0	
Horizontal Condenser	UNIT											
4 = R-410A	REFRIGERANT											
A = Air Conditioner												
H = Heat Pump				TYPE								
3 = 13 SEER												
4 = 14 SEER				NOMINAL EFFICIENCY								
18 = 18,000 BTUH = 1-1/2 tons												
24 = 24,000 BTUH = 2 tons												
30 = 30,000 BTUH = 2-1/2 tons												
36 = 36,000 BTUH = 3 tons												
42 = 42,000 BTUH = 3-1/2 tons												
48 = 48,000 BTUH = 4 tons												
60 = 60,000 BTUH = 5 tons				NOMINAL CAPACITY								
A = Standard Grille							FEATURES					
K = 208/230-1-60												
H = 208/230-3-60												
L = 460-3-60										VOLTAGE		
Sales Code												
Engineering Revision												
Extra Digit												
Extra Digit												

ACCESSORIES PART NUMBER IDENTIFICATION GUIDE									
Digit Position:	1	2	3	4	5	6, 7	8, 9	10, 11	
Example Part Number:	N	A	S	A	0	01	01	CH	
N = Non-Branded	BRANDING								
A = Accessory	PRODUCT GROUP								
S = Split System (AC & HP)				KIT USAGE					
A = Original									
B = 2nd Generation				MAJOR SERIES					
0 = Generic or Not Applicable									
2 = R-22									
4 = R-410A				REFRIGERANT					
Product Identifier Number									
Package Quantity									
Type of Kit (Example: CH = Crankcase Heater)									

PHYSICAL DATA

UNIT HC4A3	18	24A*A1	30	36	48A*A1	60
NOMINAL CAPACITY Tons (kg)	1.5 (1360.8)	2.0 (1814.4)	2.5 (2268.0)	3.0 (2721.6)	4.0 (3628.8)	5.0 (4536.0)
OPERATING WEIGHT lb (kg)	155 (70)	180 (82)	200 (91)	218 (99)	284 (129)	294 (134)
REFRIGERANT TYPE	R-410A					
METERING DEVICE	TXV					
CHARGE* lb (kg)	6.3 (2.86)	6.5 (2.95)	8.7 (3.95)	8.7 (3.95)	12.0 (5.45)	12.0 (5.45)
		24A*A2 6.0 (2.73)			48A*A2 11.5 (5.23)	
Note: A*A1 and A*A2 Indicates AKA, AHA, or ALA						
COMPRESSOR						
Type	Scroll					
Oil Charge (POE -oz)	25.0	25.0	25.0	25.0	42.0	42.0
Crankcase Heater (watts)	—	—	40	40	40	40
OUTDOOR FAN						
Rpm (Cfm)	840 (1720)	840 (1720)	850 (3900)	850 (3900)	850 (3900)	850 (3900)
Diameter in. (mm.)	18 (457)	18 (457)	24 (610)	24 (610)	24 (610)	24 (610)
No. Blades	3	3	3	3	3	3
Motor (hp)	1/8	1/8	1/4	1/4	1/4	1/4
OUTDOOR COIL						
Face Area ft ² (m ²)	5.8 (0.54)	7.3 (0.68)	12.1 (1.12)	12.1 (1.12)	14.1 (1.31)	14.1 (1.31)
No. Rows	2	2	2	2	2	2
Fins Per Inch	20	20	20	20	20	20
HIGH PRESSURE SWITCH						
Cut-In (psig)	420 ± 25	420 ± 25	420 ± 25	420 ± 25	420 ± 25	420 ± 25
Cutout (psig)	650 ± 10	650 ± 10	650 ± 10	650 ± 10	650 ± 10	650 ± 10
REFRIGERANT LINES						
Connection Type	Sweat					
Liquid Line OD in. (mm)	3/8 (10)	3/8 (10)	3/8 (10)	3/8 (10)	3/8 (10)	3/8 (10)
Vapor Line OD in. (mm)	5/8 (16)	5/8 (16)	3/4 (19)	3/4 (19)	7/8 (22)	7/8† (22)
Max Length ft. (m)	200 (61)	200 (61)	200 (61)	200 (61)	200 (61)	200 (61)
Max Lift ft. (m)**	65 (20)	65 (20)	65 (20)	65 (20)	65 (20)	65 (20)
Max Drop ft. (m)	150 (46)	150 (46)	150 (46)	150 (46)	150 (46)	150 (46)
CONTROLS						
Control Voltage‡	24 vac					
System Voltage	208/230 v	208/230 v	208/230 v	208/230 v, Single and 3 Phase,	460 v, 3 Phase	
FINISH	Gray					

* Unit shipped with full factory charge. See ARI (Air Conditioning and Refrigeration Institute) capacity table for proper charge and piston for each fan coil type.

** See Long Line Application Guideline for required accessories

† Valve connection size is 7/8 inch. Recommended line size is 1-1/8 inches.

‡ 24 v and a minimum of 40 va is provided in the fan coil unit.

FPI – Fins Per Inch

POE – Polyol Ester

VAPOR LINE SIZING AND COOLING CAPACITY LOSS R-410A AIR CONDITIONER

LONG-LINE APPLICATION: An application is considered “Long line” when the total equivalent tubing length exceeds 80ft. (24.4m) or when there is more than 20ft. (6.1m) vertical separation between indoor and outdoor units. These applications require additional accessories and system modifications for reliable system operation. The maximum allowable total equivalent length is 250ft (76.2m).

The maximum vertical separation is 200ft. (61m) when outdoor unit is above indoor unit, and 80ft. (24.4m) when the outdoor unit is below the indoor unit. Refer to Accessory Usage Guideline below for required accessories. See Long-Line Application Guideline for required piping and system modifications. Also, refer to the table below for the acceptable vapor tube diameters based on the total length to minimize the cooling capacity loss.

Unit Nominal Size (Btuh)	Acceptable Vapor Line Diameters (In. O.D.)	Cooling Capacity Loss (%) Total Equivalent Line Length (ft.)										
		Standard Application			Long Line Application Requires Accessories							
		25	50	80	80+	100	125	150	175	200	225	250
18,000 1-Stage R-410A AC	1/2	1	2	3	3	4	6	7	8	9	10	12
	5/8	0	0	1	1	1	1	2	2	3	3	3
24,000 1-Stage R-410A AC	5/8	0	1	1	1	2	3	3	4	4	5	6
	3/4	0	0	0	0	0	0	0	0	0	0	1
	7/8	0	0	0	0	0	0	0	0	0	0	1
30,000 1-Stage R-410A AC	5/8	1	2	3	3	3	4	5	6	7	8	9
	3/4	0	0	1	1	1	1	2	2	2	3	3
	7/8	0	0	0	0	0	0	1	1	1	1	1
36,000 1-Stage R-410A AC	5/8	1	2	4	4	5	6	7	9	10	11	13
	3/4	0	0	1	1	1	2	2	3	3	4	4
	7/8	0	0	0	0	0	1	1	1	1	2	2
48,000 1-Stage R-410A AC	3/4	0	1	2	2	3	4	5	5	6	7	8
	7/8	0	0	1	1	1	2	2	2	3	3	4
	1-1/8	0	0	0	0	0	0	0	0	1	1	1
60,000 1-Stage R-410A AC	3/4	1	2	4	4	5	6	7	9	10	11	12
	7/8	0	1	2	2	2	3	4	4	5	5	6
	1-1/8	0	0	0	0	1	1	1	1	1	1	2

Standard Length = 80ft. (24.4m) or less total equivalent length

Applications in this area are long line. Accessories are required as shown recommended on Long Line Application Guidelines.

Applications in this area may have height restrictions that limit allowable total equivalent length, when outdoor unit is below indoor unit See Long Line Application Guidelines.

ACCESSORY USAGE GUIDELINE

ACCESSORY	REQUIRED FOR LOW-AMBIENT COOLING APPLICATIONS (Below 55°F/12.8°C)	REQUIRED FOR LONG LINE APPLICATIONS* Over 80Ft. (24.4m)	REQUIRED FOR SEA COAST APPLICATIONS Within 2 miles (3.2km)
Compressor Start Assist Capacitor and Relay	Yes	Yes	No
Crankcase Heater	Yes	Yes	No
Evaporator Freeze Thermostat	Yes	No	No
Hard Shutoff TXV	Yes	Yes	Yes
Liquid Line Solenoid Valve	No	See Longline Application Guideline	No
Low-ambient Control	Yes	No	No
Winter Start Control	Yes	No	No

* For tubing line sets between 80 and 200 ft. and/or 20 ft. (24.4 and 61m and/or 6.1m) vertical differential, refer to Residential Split-System Longline Application Guideline.

Accessory Description and Usage (Listed Alphabetically)

1. Crankcase Heater

An electric resistance heater which mounts to the base of the compressor to keep the lubricant warm during off cycles. Improves compressor lubrication on restart and minimizes the chance of liquid slugging.

Usage Guideline:

Required in low ambient cooling applications.

Required in long line applications.

Suggested in all commercial applications.

2. Evaporator Freeze Thermostat

An SPST temperature-actuated switch that stops unit operation when evaporator reaches freeze-up conditions.

Usage Guideline:

Required when low ambient kit has been added.

3. Low-Ambient Pressure Switch Kit A long life pressure switch which is mounted to outdoor unit service valve. It is designed to cycle the outdoor fan motor in order to maintain head pressure within normal operating limits (approximately 100 psig/689.5 KpA to 225 psig/1551.3 KpA). The control will maintain working head pressure at low-ambient temperatures down to 0°F when properly installed.

Usage Guideline:

A Low-Ambient Pressure Switch or Low-Ambient Controller must be used when cooling operation is used at outdoor temperatures below 55°F (12.8°C).

4. Low-Ambient Control

A fan-speed control device activated by a temperature sensor, designed to control condenser fan motor speed in response to the saturated, condensing temperature during operation in cooling mode only. For outdoor temperatures down to -20°F (-28.9°C), it maintains condensing temperature at 100°F ±10°F (37.8°C ± -12°C).

Usage Guideline:

A Low Ambient Controller must be used when cooling operation is used at outdoor temperatures below 55°F (12.8°C).

Suggested for all commercial applications.

5. Outdoor Air Temperature Sensor

Designed for use with Thermostats listed in this publication. This device enables the thermostat to display the outdoor temperature. This device also

is required to enable special thermostat features such as auxiliary heat lock out.

Usage Guideline:

Suggested for all thermostats listed in this publication.

6. Thermostatic Expansion Valve (TXV)

A modulating flow-control valve which meters refrigerant liquid flow rate into the evaporator in response to the superheat of the refrigerant gas leaving the evaporator.

Kit includes valve, adapter tubes, and external equalizer tube. Hard shut off types are available.

NOTE: When using a hard shut off TXV with single phase reciprocating compressors, a Compressor Start Assist Capacitor and Relay is required.

Usage Guideline:

Accessory required to meet ARI rating and system reliability, where indoor not equipped.

Hard shut off TXV or LLS required in air conditioner long line applications.

Required for use on all zoning systems.

7. Time-Delay Relay

An SPST delay relay which briefly continues operation of indoor blower motor to provide additional cooling after the compressor cycles off.

NOTE: Most indoor unit controls include this feature. For those that do not, use the guideline below.

Usage Guideline:

Accessory required to meet ARI rating, where indoor not equipped.

8. Winter Start Control

This control is designed to alleviate nuisance opening of the low-pressure switch by bypassing it for the first 3 minutes of operation.

ELECTRICAL DATA

HC4A3 UNIT SIZE	V-PH-Hz	VOLTAGE RANGE*		COMPRESSOR		OUTDOOR FAN MOTOR			MIN CKT AMPS	FUSE/HACR BKR AMPS
		Min	Max	RLA	LRA	FLA	NEC Hp	kW Out		
18AKA1	208/230-1-60	187	253	9.0	48.0	0.80	0.125	0.09	12.1	20
24AKA1	208/230-1-60	187	253	12.8	58.3	0.80	0.125	0.09	16.8	25
24AKA2	208/230-1-60	187	253	13.5	58.3	0.80	0.125	0.09	17.7	25
30AKA1	208/230-1-60	187	253	14.1	73.0	1.5	0.25	0.19	19.1	30
36AKA1	208/230-1-60	187	253	14.1	77.0	1.5	0.25	0.19	19.1	30
36AHA1	208/230-3-60	187	253	9.0	71.0	1.5	0.25	0.19	12.7	20
36ALA1	460-3-60	414	506	5.6	38.0	0.80	0.25	0.19	7.8	15
48AKA1	208/230-1-60	187	253	21.8	117.0	1.5	0.25	0.19	28.7	50
48AHA1	208/230-3-60	187	253	13.7	83.1	1.5	0.25	0.19	18.6	30
48ALA1	460-3-60	414	506	6.2	41.0	0.80	0.25	0.19	8.6	15
48AKA2	208/230-1-60	187	253	19.9	109.0	1.5	0.25	0.19	26.4	40
48AHA2	208/230-3-60	187	253	13.1	83.1	1.5	0.25	0.19	17.9	25
48ALA2	460-3-60	414	506	6.1	41.0	0.80	0.25	0.19	8.4	15
60AKA1	208/230-1-60	187	253	26.4	134.0	1.5	0.25	0.19	34.5	60
60AHA1	208/230-3-60	187	253	16.0	110.0	1.5	0.25	0.19	21.5	35
60ALA1	460-3-60	414	506	7.8	52.0	0.80	0.25	0.19	10.6	15
60AKA2	208/230-1-60	187	253	26.4	134.0	1.5	0.25	0.19	34.5	60
60AHA2	208/230-3-60	187	253	15.0	110.0	1.5	0.25	0.19	21.5	30
60ALA2	460-3-60	414	506	7.8	52.0	0.80	0.25	0.19	10.6	15

* Permissible limits of the voltage range at which the unit will operate satisfactorily

- FLA – Full Load Amps
- HACR – Heating, Air Conditioning, Refrigeration
- LRA – Locked Rotor Amps
- NEC – National Electrical Code
- RLA – Rated Load Amps (compressor)

NOTE: Control circuit is 24-V on all units and requires external power source. Copper wire must be used from service disconnect to unit. All motors/compressors contain internal overload protection.

SOUND LEVEL*

Unit Size	Standard Rating (dB)	Standard Rating (dB) with Sound Jacket	Typical Octave Band Spectrum (dBA) (without tone adjustment)						
			125	250	500	1000	2000	4000	8000
18	70		51.5	56.5	63.5	62.5	60.5	57.0	45.5
		69	50.0	57.0	60.5	62.0	60.0	56.0	44.5
24	73		59.5	64.0	65.5	68.5	61.0	57.0	46.0
		73	56.0	64.0	66.0	69.0	62.5	58.0	47.5
30	74		58.5	62.0	65.5	66.5	66.5	65.0	58.0
		74	59.0	62.5	65.5	66.5	67.0	65.0	58.0
36	76		59.0	64.5	70.5	70.5	67.0	65.0	56.5
		74	59.0	63.0	64.5	69.5	66.5	64.5	56.0
48	74		63.0	64.5	67.5	67.5	65.5	63.0	55.0
		73	63.0	64.5	67.5	67.5	65.5	63.0	55.0
60	74		60.5	62.5	65.5	64.5	64.0	62.5	53.5
		73	60.5	62.0	65.0	64.0	63.5	62.0	53.5

CHARGING SUBCOOLING (TXV-TYPE EXPANSION DEVICE)

UNIT SIZE-VOLTAGE, SERIES	REQUIRED SUBCOOLING °F (°C)
18	12 (6.7)
24	12 (6.7)
30	12 (6.7)
36	12 (6.7)
48	12 (6.7)
60	12 (6.7)

**Sound Rating tested in accordance with ARI Standard 270-95 (not listed with ARI).

DIMENSIONS

UNIT	SERIES	ELECTRICAL CHARACTERISTICS				A	B	C	D	E	F	G	H	J	K	L	M	N	P	OPERATING WEIGHT(lbs)	SHIPPING WEIGHT(lbs)	SHIPPING DIMENSIONS (L x W x H)		
HC4A318**A	1	X	O	O	O	25 1/8"	36 15/16"	14 9/16"	16"	23 7/16"	17 3/16"	17 1/8"	22"	13"	6 5/8"	11 1/4"	5/8"	2 15/16"	6"	155	171	42 9/10" X 18" X 28 1/10"		
HC4A324**A	1,2	X	O	O	O	31 1/8"	36 15/16"	14 9/16"	16"	23 7/16"	17 3/16"	23 1/8"	28"	14"	6 3/4"	11 5/8"	5/8"	2 15/16"	6"	180	198	42 9/10" X 18" X 34 1/10"		
HC4A330**A	1	X	O	O	O	37 3/16"	44 9/16"	17 1/16"	18 7/16"	30 1/2"	19 5/8"	29 3/16"	34 1/16"	13 11/16"	8 1/8"	15 7/8"	3/4"	3 7/16"	6 1/2"	200	223	50 1/2" X 20 1/2" X 40 2/10"		
HC4A336**A	1	X	O	X	X	37 3/16"	44 9/16"	17 1/16"	18 7/16"	30 1/2"	19 5/8"	29 3/16"	34 1/16"	13 11/16"	8 1/8"	15 7/8"	3/4"	3 7/16"	6 1/2"	218	240	50 1/2" X 20 1/2" X 40 2/10"		
HC4A348**A	1,2	X	O	X	X	43 3/16"	44 9/16"	17 1/16"	18 7/16"	30 1/2"	19 5/8"	35 3/16"	40 1/16"	14 1/2"	8 1/2"	18 7/8"	7/8"	3 7/16"	6 1/2"	284	309	50 1/2" X 20 1/2" X 46 2/10"		
HC4A360**A	1,2	X	O	X	X	43 3/16"	44 9/16"	17 1/16"	18 7/16"	30 1/2"	19 5/8"	35 3/16"	40 1/16"	14 1/2"	8 1/2"	18 7/8"	7/8"	3 7/16"	6 1/2"	294	319	50 1/2" X 20 1/2" X 46 2/10"		

208-230-160	230-160	208/230-360	460-360
-------------	---------	-------------	---------

X = YES
O = NO

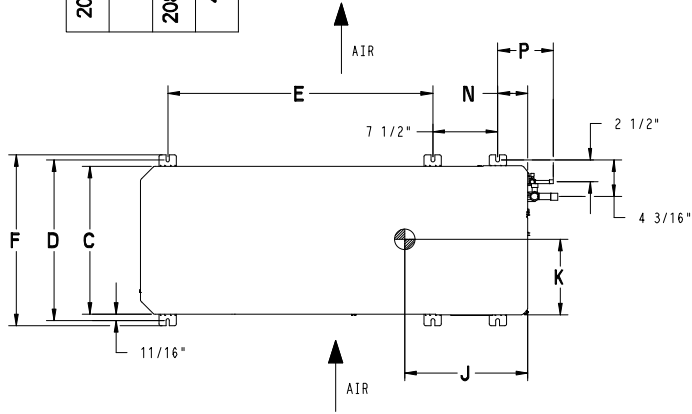

1. REQUIRED CLEARANCES: WITH COIL FACING WALL; ALLOW 6" MIN CLEARANCE ON COIL SIDE AND COIL END AND 36" MIN CLEARANCE ON COMPRESSOR END AND FAN SIDE. WITH FAN FACING WALL; ALLOW 8" MIN CLEARANCE ON FAN SIDE AND COIL END AND 36" MIN CLEARANCE ON COMPRESSOR END AND COIL SIDE. WITH MULTI UNIT APPLICATION; ARRANGE UNITS SO DISCHARGE OF ONE DOES NOT ENTER INLET OF ANOTHER.
2. MINIMUM OUTDOOR OPERATING AMBIENT IN COOLING MODE IS 55°F, MAX. 125°F.
3. SERIES DESIGNATION IS THE 10TH POSITION OF THE UNIT MODEL NUMBER.
4. CENTER OF GRAVITY
5. ALL DIMENSIONS ARE IN "INCHES" UNLESS NOTED.

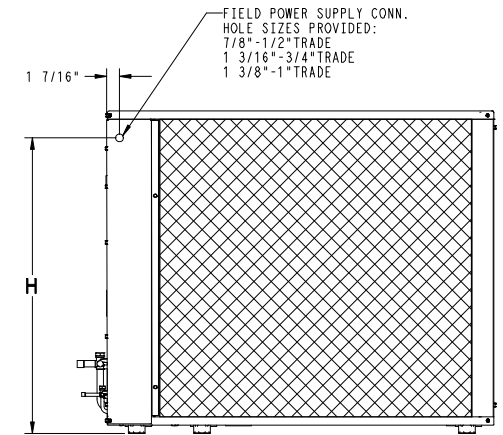
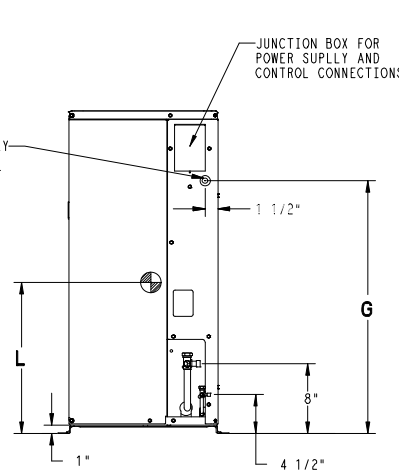
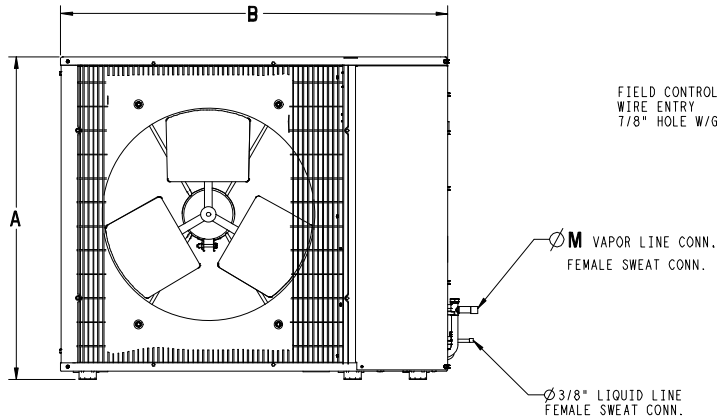

UNIT SIZE	MINIMUM MOUNTING PAD DIMENSIONS
18,24	23" X 42"
30,36,48,60	24" X 50"

MEASUREMENT- ENGLISH
SD4834-4-B

Specifications subject to change without notice.

421 21 9701 02

DIMENSIONS

UNIT	SERIES	ELECTRICAL CHARACTERISTICS				A	B	C	D	E	F	G	H	J	K	L	M	N	P	OPERATING WEIGHT(KG)	SHIPPING WEIGHT(KG)	SHIPPING DIMENSIONS (L x W x H)
HC4A318**A	1	X	O	O	O	638.2	938.2	369.9	406.4	595.3	436.6	435.0	558.8	330.2	168.3	285.8	15.9	74.6	152.4	70.4	77.7	1090.2 X 457.7 X 714.3
HC4A324**A	1,2	X	O	O	O	790.6	938.2	369.9	406.4	595.3	436.6	587.4	711.2	355.6	171.5	295.3	15.9	74.6	152.4	81.8	90.0	1090.2 X 457.7 X 866.7
HC4A330**A	1	X	O	O	O	944.6	1131.9	433.4	468.3	774.7	498.5	741.4	865.2	347.7	206.4	403.2	19.0	87.3	165.1	90.9	101.4	1282.7 X 520.7 X 1020.7
HC4A336**A	1	X	O	X	X	944.6	1131.9	433.4	468.3	774.7	498.5	741.4	865.2	347.7	206.4	403.2	19.0	87.3	165.1	99.0	109.0	1282.7 X 520.7 X 1020.7
HC4A348**A	1,2	X	O	X	X	1097.0	1131.9	433.4	468.3	774.7	498.5	893.8	1017.6	368.3	215.9	479.4	22.2	87.3	165.1	129.0	140.4	1282.7 X 520.7 X 1173.1
HC4A360**A	1,2	X	O	X	X	1097.0	1131.9	433.4	468.3	774.7	498.5	893.8	1017.6	368.3	215.9	479.4	22.2	87.3	165.1	133.6	145.0	1282.7 X 520.7 X 1173.1

208-230-160	230-160	208/230-3-60	460-3-60
-------------	---------	--------------	----------

X = YES
O = NO

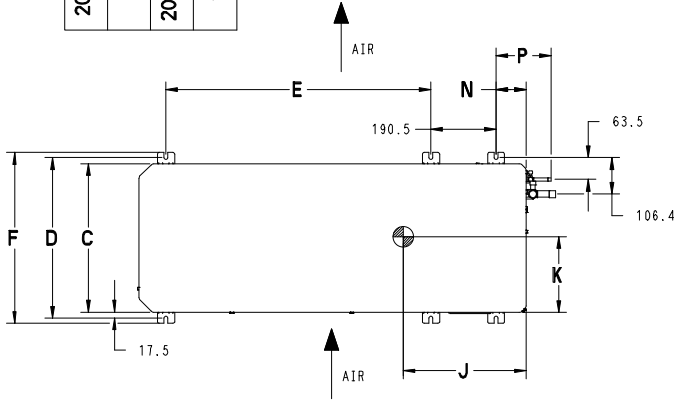

- REQUIRED CLEARANCES: WITH COIL FACING WALL; ALLOW 152.4 MIN CLEARANCE ON COIL SIDE AND COIL END AND 914.4 MIN CLEARANCE ON COMPRESSOR END AND FAN SIDE. WITH FAN FACING WALL; ALLOW 203.2 MIN CLEARANCE ON FAN SIDE AND COIL END AND 914.4 MIN CLEARANCE ON COMPRESSOR END AND COIL SIDE. WITH MULTI UNIT APPLICATION; ARRANGE UNITS SO DISCHARGE OF ONE DOES NOT ENTER INLET OF ANOTHER.
- MINIMUM OUTDOOR OPERATING AMBIENT IN COOLING MODE IS 12.8°C, MAX. 51.7°C.
- SERIES DESIGNATION IS THE 10TH POSITION OF THE UNIT MODEL NUMBER.
- CENTER OF GRAVITY
- ALL DIMENSIONS ARE IN "MM" UNLESS NOTED.

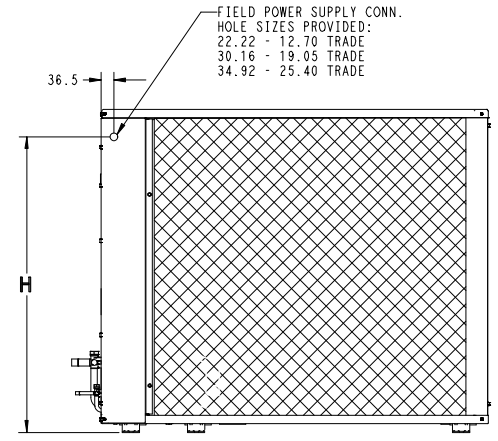
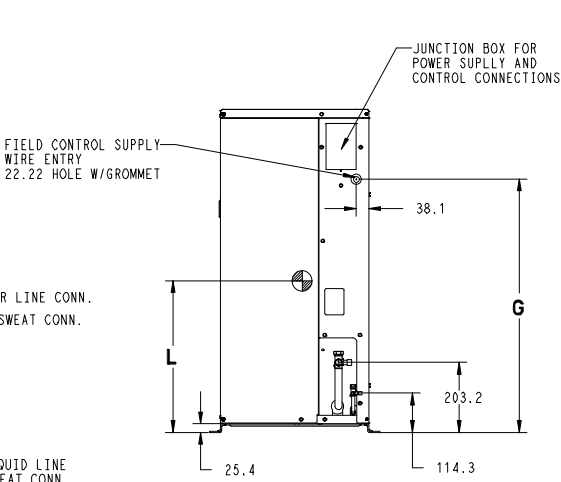
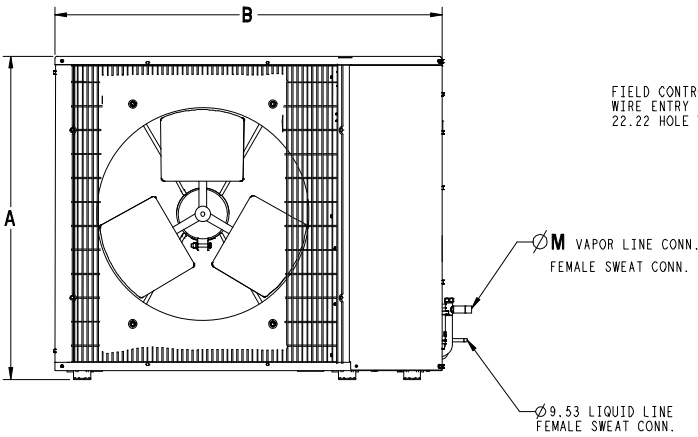

UNIT SIZE	MINIMUM MOUNTING PAD DIMENSIONS
18,24	584.2 X 1066.8
30,36,48,60	609.6 X 1270.0

MEASUREMENT- METRIC "SI"
SD4834-4-B

COOLING PERFORMANCE FOR COMBINATION RATINGS Indoor Models

For complete ratings information, use the AHRI website directory search: www.AHRIdirectory.org.
New ratings may be listed online before Specification Sheets are updated.

Outdoor Model	Indoor Model (‡ tested combo)	Furnace Model	Factory Installed	Cooling 95° F (35° C)			SEER		
				BTU/hr	S/T	EER	Factory	w/ Field TDR	w/ Field TXV
HC4A318AKA	‡ED*4X18B**	†	TXV	17,000	0.74	11.00		13.00	
	EHD4X24A**	*8MV*0701412**	TDR&TXV	17,400	0.74	12.00	14.50		
	EHD4X24A**	*8MV*0901716**	TDR&TXV	17,400	0.74	12.00	14.50		
	EHD4X24A**	*8MX*0451408**	TDR&TXV	17,400	0.74	12.00	14.50		
	EHD4X24A**	NOMV106D12*	TDR&TXV	17,400	0.74	12.00	14.50		
	EHD4X24A**	OLV098A12A	TDR&TXV	17,400	0.74	12.00	14.50		
	EHD4X24A**	OMV098J12A	TDR&TXV	17,400	0.74	12.00	14.50		
	EN(A,D)4X18*14**	*8MV*0701412**	TDR&TXV	17,000	0.74	12.00	14.50		
	EN(A,D)4X18*14**	*8MX*0451408**	TDR&TXV	17,000	0.74	12.00	14.50		
	EN(A,D)4X18*14**	†	TXV	17,000	0.74	11.00		13.00	
	EN(A,D)4X19*17**	*8MV*0901716**	TDR&TXV	17,000	0.74	12.00	14.50		
	EN(A,D)4X19*17**	NOMV106D12*	TDR&TXV	17,400	0.74	12.00	14.50		
	EN(A,D)4X19*17**	OLV098A12A	TDR&TXV	17,400	0.74	12.00	14.50		
	EN(A,D)4X19*17**	OMV098J12A	TDR&TXV	17,400	0.74	12.00	14.50		
	EN(A,D)4X19*17**	†	TXV	17,000	0.74	11.00		13.00	
	EN(A,D)4X24*14**	*8MV*0701412**	TDR&TXV	17,400	0.74	12.00	14.50		
	EN(A,D)4X24*14**	*8MX*0451408**	TDR&TXV	17,400	0.74	12.00	14.50		
	EN(A,D)4X24*14**	†	TXV	17,400	0.74	11.00		13.00	
	EN(A,D)4X24*17**	*8MV*0901716**	TDR&TXV	17,400	0.74	12.00	14.50		
	EN(A,D)4X24*17**	NOMV106D12*	TDR&TXV	17,400	0.74	12.00	14.50		
	EN(A,D)4X24*17**	OLV098A12A	TDR&TXV	17,400	0.74	12.00	14.50		
	EN(A,D)4X24*17**	OMV098J12A	TDR&TXV	17,400	0.74	12.00	14.50		
	EN(A,D)4X24*17**	†	TXV	17,400	0.74	11.00		13.00	
	ENH4X24*17**	*8MPV050	TDR&TXV	17,400	0.74	12.00	14.50		
	ENH4X24*17**	*8MV*0701412**	TDR&TXV	17,400	0.74	12.00	14.50		
	ENH4X24*17**	*8MV*0901716**	TDR&TXV	17,400	0.74	12.00	14.50		
	ENH4X24*17**	*8MX*0451408**	TDR&TXV	17,400	0.74	12.00	14.50		
	ENH4X24*17**	*9MPV050	TDR&TXV	17,400	0.74	12.00	14.50		
	ENH4X24*17**	*9MPV075	TDR&TXV	17,400	0.74	12.00	14.50		
	ENH4X24*17**	*9MVX040	TDR&TXV	17,400	0.74	12.00	14.50		
	ENH4X24*17**	*9MVX060	TDR&TXV	17,400	0.74	12.00	14.50		
	ENH4X24*17**	NOMV106D12*	TDR&TXV	17,400	0.74	12.00	14.50		
	ENH4X24*17**	OLV098A12A	TDR&TXV	17,400	0.74	12.00	14.50		
	ENH4X24*17**	OMV098J12A	TDR&TXV	17,400	0.74	12.00	14.50		
ENH4X24*17**	†	TXV	17,400	0.74	11.00		13.00		
FEM4P18**A* + TXV	—	TDR	17,000	0.74	12.00			14.50	
FEM4P24**A* + TXV	—	TDR	17,400	0.74	12.00			14.50	
FS(M,U)4P18**A* + TXV	—	TDR	17,000	0.74	11.00			13.50	
FS(M,U)4P24**A* + TXV	—	TDR	17,400	0.74	11.00			13.50	
FVM4X24****	—	TDR&TXV	17,400	0.74	12.00	14.50			
FXM4X18**A*	—	TDR&TXV	17,600	0.74	12.00	14.50			
FXM4X24**A*	—	TDR&TXV	17,800	0.74	12.00	14.50			
HC4A324AKA	‡ED*4X24B**	†	TXV	23,200	0.70	11.00		13.00	
	EHD4X24A**	*8MV*0701412**	TDR&TXV	23,200	0.70	12.00	14.50		
	EHD4X24A**	*8MV*0901716**	TDR&TXV	23,200	0.70	12.00	14.50		
	EHD4X24A**	*8MV*1102120**	TDR&TXV	23,200	0.70	12.00	14.50		
	EHD4X24A**	*8MV*1352422**	TDR&TXV	23,200	0.70	12.00	14.50		
	EHD4X24A**	*8MX*0451408**	TDR&TXV	23,200	0.70	12.00	14.50		
	EHD4X24A**	NOMV106D12*	TDR&TXV	23,200	0.70	12.00	14.50		
	EHD4X24A**	OLV098A12A	TDR&TXV	23,200	0.70	12.00	14.50		
	EHD4X24A**	OMV098J12A	TDR&TXV	23,200	0.70	12.00	14.50		
	EHD4X24A**	OMV112K14A	TDR&TXV	23,200	0.70	12.00	14.50		
	EHD4X30A**	*8MV*0701412**	TDR&TXV	23,200	0.70	12.00	14.50		
	EHD4X30A**	*8MV*0901716**	TDR&TXV	23,400	0.70	12.00	14.50		
	EHD4X30A**	*8MV*1102120**	TDR&TXV	23,400	0.70	12.00	14.50		
	EHD4X30A**	*8MV*1352422**	TDR&TXV	23,400	0.70	12.00	14.50		

2009 ENERGY STAR compliance for combinations with both: SEER 14.50 (3 phase = 14.00) or higher and EER 12.00 or higher.

† For coils not listed with a matching furnace or blower, coil rating applies with any indoor blower device.

- continued on next page -

COOLING PERFORMANCE FOR COMBINATION RATINGS (continued) Indoor Models

For complete ratings information, use the AHRI website directory search: www.AHRI.org.
New ratings may be listed online before Specification Sheets are updated.

Outdoor Model	Indoor Model († tested combo)	Furnace Model	Factory Installed	Cooling 95° F (35° C)			SEER		
				BTU/hr	S/T	EER	Factory	w/ Field TDR	w/ Field TXV
HC4A324AKA (continued)	EHD4X30A**	*8MX*0451408**	TDR&TXV	23,400	0.70	12.00	14.50		
	EHD4X30A**	NOMV106D12*	TDR&TXV	23,200	0.70	12.00	14.50		
	EHD4X30A**	OLV098A12A	TDR&TXV	23,400	0.70	12.00	14.50		
	EHD4X30A**	OMV098J12A	TDR&TXV	23,400	0.70	12.00	14.50		
	EHD4X30A**	OMV112K14A	TDR&TXV	23,400	0.70	12.00	14.50		
	EN(A,D)4X24*14**	*8MV*0701412**	TDR&TXV	23,000	0.70	12.00	14.50		
	EN(A,D)4X24*14**	*8MX*0451408**	TDR&TXV	23,200	0.70	12.00	14.50		
	EN(A,D)4X24*14**	†	TXV	23,200	0.70	11.00		13.00	
	EN(A,D)4X24*17**	*8MV*0901716**	TDR&TXV	23,200	0.70	12.00	14.50		
	EN(A,D)4X24*17**	NOMV106D12*	TDR&TXV	23,000	0.70	12.00	14.50		
	EN(A,D)4X24*17**	OLV098A12A	TDR&TXV	23,200	0.70	12.00	14.50		
	EN(A,D)4X24*17**	OMV098J12A	TDR&TXV	23,200	0.70	12.00	14.50		
	EN(A,D)4X24*17**	OMV112K14A	TDR&TXV	23,200	0.70	12.00	14.50		
	EN(A,D)4X24*17**	†	TXV	23,200	0.70	11.00		13.00	
	EN(A,D)4X30*14**	*8MV*0701412**	TDR&TXV	23,200	0.70	12.00	14.50		
	EN(A,D)4X30*14**	*8MX*0451408**	TDR&TXV	23,400	0.70	12.00	14.50		
	EN(A,D)4X30*14**	†	TXV	23,400	0.70	11.00		13.00	
	EN(A,D)4X30*17**	*8MV*0901716**	TDR&TXV	23,200	0.70	12.00	14.50		
	EN(A,D)4X30*17**	NOMV106D12*	TDR&TXV	23,200	0.70	12.00	14.50		
	EN(A,D)4X30*17**	OLV098A12A	TDR&TXV	23,400	0.70	12.00	14.50		
	EN(A,D)4X30*17**	OMV098J12A	TDR&TXV	23,400	0.70	12.00	14.50		
	EN(A,D)4X30*17**	OMV112K14A	TDR&TXV	23,400	0.70	12.00	14.50		
	EN(A,D)4X30*17**	†	TXV	23,400	0.70	11.00		13.00	
	EN(A,D)4X31*17**	*8MV*0901716**	TDR&TXV	23,600	0.70	12.00	14.50		
	EN(A,D)4X31*17**	NOMV106D12*	TDR&TXV	23,600	0.70	12.00	14.50		
	EN(A,D)4X31*17**	OLV098A12A	TDR&TXV	23,600	0.70	12.00	14.50		
	EN(A,D)4X31*17**	OMV098J12A	TDR&TXV	23,600	0.70	12.00	14.50		
	EN(A,D)4X31*17**	OMV112K14A	TDR&TXV	23,600	0.70	12.00	14.50		
	EN(A,D)4X31*17**	†	TXV	23,600	0.70	11.00		13.00	
	ENH4X24*17**	*8MPV050	TDR&TXV	23,200	0.70	11.50	14.00		
	ENH4X24*17**	*8MPV075	TDR&TXV	23,200	0.70	12.00	14.50		
	ENH4X24*17**	*8MPV100	TDR&TXV	23,200	0.70	12.00	14.50		
	ENH4X24*17**	*8MPV125	TDR&TXV	23,200	0.70	12.00	14.50		
	ENH4X24*17**	*8MV*0701412**	TDR&TXV	23,000	0.70	12.00	14.50		
	ENH4X24*17**	*8MV*0901716**	TDR&TXV	23,200	0.70	12.00	14.50		
	ENH4X24*17**	*8MV*1102120**	TDR&TXV	23,200	0.70	12.00	14.50		
	ENH4X24*17**	*8MV*1352422**	TDR&TXV	23,200	0.70	12.00	14.50		
	ENH4X24*17**	*8MX*0451408**	TDR&TXV	23,200	0.70	12.00	14.50		
	ENH4X24*17**	*9MPV050	TDR&TXV	23,200	0.70	11.50	14.00		
	ENH4X24*17**	*9MPV075	TDR&TXV	23,200	0.70	11.50	14.00		
	ENH4X24*17**	*9MPV100	TDR&TXV	23,200	0.70	11.50	14.00		
	ENH4X24*17**	*9MPV125	TDR&TXV	23,200	0.70	12.00	14.50		
	ENH4X24*17**	*9MVX040	TDR&TXV	23,200	0.70	11.50	14.00		
	ENH4X24*17**	*9MVX060	TDR&TXV	23,200	0.70	11.50	14.00		
	ENH4X24*17**	*9MVX080	TDR&TXV	23,200	0.70	12.00	14.50		
	ENH4X24*17**	*9MVX100	TDR&TXV	23,200	0.70	12.00	14.50		
	ENH4X24*17**	MV08B15**B*	TDR&TXV	23,200	0.70	12.00	14.50		
	ENH4X24*17**	MV12F19**B*	TDR&TXV	23,200	0.70	12.00	14.50		
ENH4X24*17**	NOMV106D12*	TDR&TXV	23,000	0.70	12.00	14.50			
ENH4X24*17**	OLV098A12A	TDR&TXV	23,200	0.70	12.00	14.50			
ENH4X24*17**	OMV098J12A	TDR&TXV	23,200	0.70	12.00	14.50			
ENH4X24*17**	OMV112K14A	TDR&TXV	23,200	0.70	12.00	14.50			
ENH4X24*17**	†	TXV	23,200	0.70	11.00		13.00		
ENH4X30*17**	*8MPV050	TDR&TXV	23,400	0.70	11.50	14.00			
ENH4X30*17**	*8MPV075	TDR&TXV	23,400	0.70	12.00	14.50			
ENH4X30*17**	*8MPV100	TDR&TXV	23,400	0.70	12.00	14.50			

2009 ENERGY STAR compliance for combinations with both: SEER 14.50 (3 phase = 14.00) or higher and EER 12.00 or higher.

† For coils not listed with a matching furnace or blower, coil rating applies with any indoor blower device.

- continued on next page -

COOLING PERFORMANCE FOR COMBINATION RATINGS (continued) Indoor Models

For complete ratings information, use the AHRI website directory search: www.AHRI.org.
New ratings may be listed online before Specification Sheets are updated.

Outdoor Model	Indoor Model († tested combo)	Furnace Model	Factory Installed	Cooling 95° F (35° C)			SEER		
				BTU/hr	S/T	EER	Factory	w/ Field TDR	w/ Field TXV
HC4A324AKA (continued)	ENH4X30*17**	*8MPV125	TDR&TXV	23,400	0.70	12.00	14.50		
	ENH4X30*17**	*8MV*0701412**	TDR&TXV	23,200	0.70	12.00	14.50		
	ENH4X30*17**	*8MV*0901716**	TDR&TXV	23,200	0.70	12.00	14.50		
	ENH4X30*17**	*8MV*1102120**	TDR&TXV	23,400	0.70	12.00	14.50		
	ENH4X30*17**	*8MV*1352422**	TDR&TXV	23,400	0.70	12.00	14.50		
	ENH4X30*17**	*8MX*0451408**	TDR&TXV	23,400	0.70	12.00	14.50		
	ENH4X30*17**	*9MPV050	TDR&TXV	23,400	0.70	12.00	14.50		
	ENH4X30*17**	*9MPV075	TDR&TXV	23,400	0.70	12.00	14.50		
	ENH4X30*17**	*9MPV100	TDR&TXV	23,400	0.70	12.00	14.50		
	ENH4X30*17**	*9MPV125	TDR&TXV	23,400	0.70	12.00	14.50		
	ENH4X30*17**	*9MVX040	TDR&TXV	23,400	0.70	12.00	14.50		
	ENH4X30*17**	*9MVX060	TDR&TXV	23,400	0.70	12.00	14.50		
	ENH4X30*17**	*9MVX080	TDR&TXV	23,400	0.70	12.00	14.50		
	ENH4X30*17**	*9MVX100	TDR&TXV	23,400	0.70	12.00	14.50		
	ENH4X30*17**	MV08B15**B*	TDR&TXV	23,400	0.70	12.00	14.50		
	ENH4X30*17**	MV12F19**B*	TDR&TXV	23,400	0.70	12.00	14.50		
	ENH4X30*17**	NOMV106D12*	TDR&TXV	23,200	0.70	12.00	14.50		
	ENH4X30*17**	OLV098A12A	TDR&TXV	23,400	0.70	12.00	14.50		
	ENH4X30*17**	OMV098J12A	TDR&TXV	23,400	0.70	12.00	14.50		
	ENH4X30*17**	OMV112K14A	TDR&TXV	23,400	0.70	12.00	14.50		
	ENH4X30*17**	†	TXV	23,400	0.70	11.00		13.00	
	ENH4X31*17**	*8MPV050	TDR&TXV	23,600	0.70	12.00	14.50		
	ENH4X31*17**	*8MPV075	TDR&TXV	23,600	0.70	12.00	14.50		
	ENH4X31*17**	*8MPV100	TDR&TXV	23,600	0.70	12.00	14.50		
	ENH4X31*17**	*8MPV125	TDR&TXV	23,600	0.70	12.00	14.50		
	ENH4X31*17**	*8MV*0701412**	TDR&TXV	23,600	0.70	12.00	14.50		
	ENH4X31*17**	*8MV*0901716**	TDR&TXV	23,600	0.70	12.00	14.50		
	ENH4X31*17**	*8MV*1102120**	TDR&TXV	23,600	0.70	12.00	14.50		
	ENH4X31*17**	*8MV*1352422**	TDR&TXV	23,600	0.70	12.00	14.50		
	ENH4X31*17**	*8MX*0451408**	TDR&TXV	23,600	0.70	12.00	14.50		
	ENH4X31*17**	*9MPV050	TDR&TXV	23,600	0.70	12.00	14.50		
	ENH4X31*17**	*9MPV075	TDR&TXV	23,600	0.70	12.00	14.50		
	ENH4X31*17**	*9MPV100	TDR&TXV	23,600	0.70	12.00	14.50		
	ENH4X31*17**	*9MPV125	TDR&TXV	23,600	0.70	12.00	14.50		
	ENH4X31*17**	*9MVX040	TDR&TXV	23,600	0.70	12.00	14.50		
	ENH4X31*17**	*9MVX060	TDR&TXV	23,600	0.70	12.00	14.50		
	ENH4X31*17**	*9MVX080	TDR&TXV	23,600	0.70	12.00	14.50		
	ENH4X31*17**	*9MVX100	TDR&TXV	23,600	0.70	12.00	14.50		
	ENH4X31*17**	MV08B15**B*	TDR&TXV	23,600	0.70	12.00	14.50		
	ENH4X31*17**	MV12F19**B*	TDR&TXV	23,600	0.70	12.00	14.50		
	ENH4X31*17**	NOMV106D12*	TDR&TXV	23,600	0.70	12.00	14.50		
	ENH4X31*17**	OLV098A12A	TDR&TXV	23,600	0.70	12.00	14.50		
ENH4X31*17**	OMV098J12A	TDR&TXV	23,600	0.70	12.00	14.50			
ENH4X31*17**	OMV112K14A	TDR&TXV	23,600	0.70	12.00	14.50			
ENH4X31*17**	†	TXV	23,600	0.70	11.00		13.00		
FEM4P24**A* + TXV	—	TDR	23,000	0.70	11.50			13.50	
FEM4P30**A* + TXV	—	TDR	23,400	0.70	12.00			14.50	
FS(M,U)4P24**A* + TXV	—	TDR	23,200	0.70	11.50			14.00	
FS(M,U)4P30**A* + TXV	—	TDR	23,400	0.70	11.50			13.50	
FVM4X24***	—	TDR&TXV	23,400	0.70	12.00	14.50			
FVM4X36***	—	TDR&TXV	23,600	0.70	12.00	14.50			
FXM4X24**A*	—	TDR&TXV	23,400	0.70	12.00	14.50			
FXM4X30**A*	—	TDR&TXV	23,600	0.70	12.00	14.50			
HC4A330AKA	‡ED*4X30B**	†	TXV	29,000	0.76	11.00		13.00	
	EHD4X30A**	*8MV*0701412**	TDR&TXV	29,000	0.76	12.00	14.50		
	EHD4X30A**	*8MV*0901716**	TDR&TXV	29,000	0.76	12.00	14.50		
	EHD4X30A**	*8MV*1102120**	TDR&TXV	29,000	0.76	12.00	14.50		
	EHD4X30A**	*8MV*1352422**	TDR&TXV	29,000	0.76	12.00	14.50		

2009 ENERGY STAR compliance for combinations with both: SEER 14.50 (3 phase = 14.00) or higher and EER 12.00 or higher.

† For coils not listed with a matching furnace or blower, coil rating applies with any indoor blower device.

- continued on next page -

COOLING PERFORMANCE FOR COMBINATION RATINGS (continued) Indoor Models

For complete ratings information, use the AHRI website directory search: www.AHRI.org.
 New ratings may be listed online before Specification Sheets are updated.

Outdoor Model	Indoor Model († tested combo)	Furnace Model	Factory Installed	Cooling 95° F (35° C)			SEER		
				BTU/hr	S/T	EER	Factory	w/ Field TDR	w/ Field TXV
HC4A330AKA (continued)	EHD4X30A**	*8MX*0701716**	TDR&TXV	29,000	0.76	12.00	14.50		
	EHD4X30A**	*8MX*0902116**	TDR&TXV	29,000	0.76	12.00	14.50		
	EHD4X30A**	NOMV106D12*	TDR&TXV	29,000	0.76	12.00	14.50		
	EHD4X36A**	*8MV*0701412**	TDR&TXV	29,200	0.76	12.00	14.50		
	EHD4X36A**	*8MV*0901716**	TDR&TXV	29,200	0.76	12.00	14.50		
	EHD4X36A**	*8MV*1102120**	TDR&TXV	29,200	0.76	12.00	14.50		
	EHD4X36A**	*8MV*1352422**	TDR&TXV	29,200	0.76	12.00	14.50		
	EHD4X36A**	*8MX*0701716**	TDR&TXV	29,200	0.76	12.00	14.50		
	EHD4X36A**	*8MX*0902116**	TDR&TXV	29,200	0.76	12.00	14.50		
	EHD4X36A**	NOMV106D12*	TDR&TXV	29,200	0.76	12.00	14.50		
	EN(A,D)4X30*14**	*8MV*0701412**	TDR&TXV	29,000	0.76	12.00	14.50		
	EN(A,D)4X30*14**	†	TXV	29,000	0.76	11.00		13.00	
	EN(A,D)4X30*17**	*8MV*0901716**	TDR&TXV	29,000	0.76	12.00	14.50		
	EN(A,D)4X30*17**	*8MX*0701716**	TDR&TXV	29,000	0.76	12.00	14.50		
	EN(A,D)4X30*17**	NOMV106D12*	TDR&TXV	29,000	0.76	12.00	14.50		
	EN(A,D)4X30*17**	OLV098A12A	TDR&TXV	29,000	0.76	12.00	14.50		
	EN(A,D)4X30*17**	OMV098J12A	TDR&TXV	29,000	0.76	12.00	14.50		
	EN(A,D)4X30*17**	OMV112K14A	TDR&TXV	29,000	0.76	12.00	14.50		
	EN(A,D)4X30*17**	†	TXV	29,000	0.76	11.00		13.00	
	EN(A,D)4X31*17**	*8MV*0901716**	TDR&TXV	29,400	0.76	12.00	14.50		
	EN(A,D)4X31*17**	*8MX*0701716**	TDR&TXV	29,400	0.76	12.00	14.50		
	EN(A,D)4X31*17**	NOMV106D12*	TDR&TXV	29,400	0.76	12.00	14.50		
	EN(A,D)4X31*17**	OLV098A12A	TDR&TXV	29,400	0.76	12.00	14.50		
	EN(A,D)4X31*17**	OMV098J12A	TDR&TXV	29,400	0.76	12.00	14.50		
	EN(A,D)4X31*17**	OMV112K14A	TDR&TXV	29,400	0.76	12.00	14.50		
	EN(A,D)4X31*17**	†	TXV	29,400	0.76	11.00		13.00	
	EN(A,D)4X36*21**	*8MV*1102120**	TDR&TXV	29,200	0.76	12.00	14.50		
	EN(A,D)4X36*21**	*8MX*0902116**	TDR&TXV	29,200	0.76	12.00	14.50		
	EN(A,D)4X36*21**	OLV112A16A	TDR&TXV	29,200	0.76	12.00	14.50		
	EN(A,D)4X36*21**	†	TXV	29,200	0.76	11.00		13.00	
	EN(A,D)4X37*17**	*8MV*0901716**	TDR&TXV	29,600	0.76	12.00	14.50		
	EN(A,D)4X37*17**	*8MX*0701716**	TDR&TXV	29,600	0.76	12.00	14.50		
	EN(A,D)4X37*17**	NOMV106D12*	TDR&TXV	29,600	0.76	12.00	14.50		
	EN(A,D)4X37*17**	OLV098A12A	TDR&TXV	29,600	0.76	12.00	14.50		
	EN(A,D)4X37*17**	OMV098J12A	TDR&TXV	29,600	0.76	12.00	14.50		
	EN(A,D)4X37*17**	OMV112K14A	TDR&TXV	29,600	0.76	12.00	14.50		
	EN(A,D)4X37*17**	†	TXV	29,600	0.76	11.00		13.00	
	EN(A,D,W)4X36*17**	*8MV*0901716**	TDR&TXV	29,200	0.76	12.00	14.50		
	EN(A,D,W)4X36*17**	*8MX*0701716**	TDR&TXV	29,200	0.76	12.00	14.50		
	EN(A,D,W)4X36*17**	NOMV106D12*	TDR&TXV	29,000	0.76	12.00	14.50		
	EN(A,D,W)4X36*17**	OLV098A12A	TDR&TXV	29,200	0.76	12.00	14.50		
	EN(A,D,W)4X36*17**	OMV098J12A	TDR&TXV	29,200	0.76	12.00	14.50		
	EN(A,D,W)4X36*17**	OMV112K14A	TDR&TXV	29,200	0.76	12.00	14.50		
	EN(A,D,W)4X36*17**	†	TXV	29,200	0.76	11.00		13.00	
	ENH4X30*17**	*8MPV050	TDR&TXV	29,000	0.76	12.00	14.15		
ENH4X30*17**	*8MPV075	TDR&TXV	29,000	0.76	12.00	14.50			
ENH4X30*17**	*8MPV100	TDR&TXV	29,000	0.76	12.00	14.50			
ENH4X30*17**	*8MPV125	TDR&TXV	29,000	0.76	12.00	14.50			
ENH4X30*17**	*8MV*0701412**	TDR&TXV	29,000	0.76	12.00	14.50			
ENH4X30*17**	*8MV*0901716**	TDR&TXV	29,000	0.76	12.00	14.50			
ENH4X30*17**	*8MV*1102120**	TDR&TXV	29,000	0.76	12.00	14.50			
ENH4X30*17**	*8MV*1352422**	TDR&TXV	29,000	0.76	12.00	14.50			
ENH4X30*17**	*8MX*0701716**	TDR&TXV	29,000	0.76	12.00	14.50			
ENH4X30*17**	*8MX*0902116**	TDR&TXV	29,000	0.76	12.00	14.50			
ENH4X30*17**	*9MPV050	TDR&TXV	29,000	0.76	11.50	14.00			
ENH4X30*17**	*9MPV075	TDR&TXV	29,000	0.76	12.00	14.50			

2009 ENERGY STAR compliance for combinations with both: SEER 14.50 (3 phase = 14.00) or higher and EER 12.00 or higher.

† For coils not listed with a matching furnace or blower, coil rating applies with any indoor blower device.

- continued on next page -

COOLING PERFORMANCE FOR COMBINATION RATINGS (continued) Indoor Models

For complete ratings information, use the AHRI website directory search: www.AHRIdirectory.org.
New ratings may be listed online before Specification Sheets are updated.

Outdoor Model	Indoor Model († tested combo)	Furnace Model	Factory Installed	Cooling 95° F (35° C)			SEER		
				BTU/hr	S/T	EER	Factory	w/ Field TDR	w/ Field TXV
HC4A330AKA (continued)	ENH4X30*17**	*9MPV100	TDR&TXV	29,000	0.76	12.00	14.50		
	ENH4X30*17**	*9MPV125	TDR&TXV	29,000	0.76	12.00	14.50		
	ENH4X30*17**	*9MVX040	TDR&TXV	29,000	0.76	11.50	14.00		
	ENH4X30*17**	*9MVX060	TDR&TXV	29,000	0.76	12.00	14.50		
	ENH4X30*17**	*9MVX080	TDR&TXV	29,000	0.76	12.00	14.50		
	ENH4X30*17**	*9MVX100	TDR&TXV	29,000	0.76	12.00	14.50		
	ENH4X30*17**	MV08B15**B*	TDR&TXV	29,000	0.76	12.00	14.50		
	ENH4X30*17**	MV12F19**B*	TDR&TXV	29,000	0.76	12.00	14.50		
	ENH4X30*17**	NOMV106D12*	TDR&TXV	29,000	0.76	12.00	14.50		
	ENH4X30*17**	OLV098A12A	TDR&TXV	29,000	0.76	12.00	14.50		
	ENH4X30*17**	OLV112A16A	TDR&TXV	29,000	0.76	12.00	14.50		
	ENH4X30*17**	OMV098J12A	TDR&TXV	29,000	0.76	12.00	14.50		
	ENH4X30*17**	OMV112K14A	TDR&TXV	29,000	0.76	12.00	14.50		
	ENH4X30*17**	†	TXV	29,000	0.76	11.00		13.00	
	ENH4X31*17**	*8MPV050	TDR&TXV	29,400	0.76	12.00	14.50		
	ENH4X31*17**	*8MPV075	TDR&TXV	29,400	0.76	12.00	14.50		
	ENH4X31*17**	*8MPV100	TDR&TXV	29,400	0.76	12.00	14.50		
	ENH4X31*17**	*8MPV125	TDR&TXV	29,400	0.76	12.00	14.50		
	ENH4X31*17**	*8MV*0701412**	TDR&TXV	29,400	0.76	12.00	14.50		
	ENH4X31*17**	*8MV*0901716**	TDR&TXV	29,400	0.76	12.00	14.50		
	ENH4X31*17**	*8MV*1102120**	TDR&TXV	29,400	0.76	12.00	14.50		
	ENH4X31*17**	*8MV*1352422**	TDR&TXV	29,400	0.76	12.00	14.50		
	ENH4X31*17**	*8MX*0701716**	TDR&TXV	29,400	0.76	12.00	14.50		
	ENH4X31*17**	*8MX*0902116**	TDR&TXV	29,400	0.76	12.00	14.50		
	ENH4X31*17**	*9MPV050	TDR&TXV	29,400	0.76	12.00	14.50		
	ENH4X31*17**	*9MPV075	TDR&TXV	29,400	0.76	12.75	14.50		
	ENH4X31*17**	*9MPV100	TDR&TXV	29,400	0.76	12.00	14.50		
	ENH4X31*17**	*9MPV125	TDR&TXV	29,400	0.76	12.00	14.50		
	ENH4X31*17**	*9MVX040	TDR&TXV	29,400	0.76	12.00	14.50		
	ENH4X31*17**	*9MVX060	TDR&TXV	29,400	0.76	12.00	14.50		
	ENH4X31*17**	*9MVX080	TDR&TXV	29,400	0.76	12.00	14.50		
	ENH4X31*17**	*9MVX100	TDR&TXV	29,400	0.76	12.00	14.50		
	ENH4X31*17**	MV08B15**B*	TDR&TXV	29,400	0.76	12.00	14.50		
	ENH4X31*17**	MV12F19**B*	TDR&TXV	29,400	0.76	12.00	14.50		
	ENH4X31*17**	NOMV106D12*	TDR&TXV	29,400	0.76	12.00	14.50		
	ENH4X31*17**	OLV098A12A	TDR&TXV	29,400	0.76	12.00	14.50		
	ENH4X31*17**	OLV112A16A	TDR&TXV	29,400	0.76	12.00	14.50		
	ENH4X31*17**	OMV098J12A	TDR&TXV	29,400	0.76	12.00	14.50		
	ENH4X31*17**	OMV112K14A	TDR&TXV	29,400	0.76	12.00	14.50		
	ENH4X31*17**	†	TXV	29,400	0.76	11.00		13.00	
	ENH4X36*17**	*8MPV050	TDR&TXV	29,200	0.76	11.50	14.00		
	ENH4X36*17**	*8MPV075	TDR&TXV	29,200	0.76	12.00	14.50		
ENH4X36*17**	*8MPV100	TDR&TXV	29,200	0.76	12.00	14.50			
ENH4X36*17**	*8MPV125	TDR&TXV	29,200	0.76	12.00	14.50			
ENH4X36*17**	*8MV*0701412**	TDR&TXV	29,200	0.76	12.00	14.50			
ENH4X36*17**	*8MV*0901716**	TDR&TXV	29,200	0.76	12.00	14.50			
ENH4X36*17**	*8MV*1102120**	TDR&TXV	29,200	0.76	12.00	14.50			
ENH4X36*17**	*8MV*1352422**	TDR&TXV	29,200	0.76	12.00	14.50			
ENH4X36*17**	*8MX*0701716**	TDR&TXV	29,200	0.76	12.00	14.50			
ENH4X36*17**	*8MX*0902116**	TDR&TXV	29,200	0.76	12.00	14.50			
ENH4X36*17**	*9MPV050	TDR&TXV	29,200	0.76	11.50	14.00			
ENH4X36*17**	*9MPV075	TDR&TXV	29,200	0.76	12.00	14.50			
ENH4X36*17**	*9MPV100	TDR&TXV	29,200	0.76	12.00	14.50			
ENH4X36*17**	*9MPV125	TDR&TXV	29,200	0.76	12.00	14.50			
ENH4X36*17**	*9MVX040	TDR&TXV	29,200	0.76	11.50	14.00			
ENH4X36*17**	*9MVX060	TDR&TXV	29,200	0.76	12.00	14.50			

2009 ENERGY STAR compliance for combinations with both: SEER 14.50 (3 phase = 14.00) or higher and EER 12.00 or higher.

† For coils not listed with a matching furnace or blower, coil rating applies with any indoor blower device.

- continued on next page -

COOLING PERFORMANCE FOR COMBINATION RATINGS (continued) Indoor Models									
For complete ratings information, use the AHRI website directory search: www.AHRI.org .									
New ratings may be listed online before Specification Sheets are updated.									
Outdoor Model	Indoor Model († tested combo)	Furnace Model	Factory Installed	Cooling 95° F (35° C)			SEER		
				BTU/hr	S/T	EER	Factory	w/ Field TDR	w/ Field TXV
HC4A330AKA (continued)	ENH4X36*17**	*9MVX080	TDR&TXV	29,200	0.76	12.00	14.50		
	ENH4X36*17**	*9MVX100	TDR&TXV	29,200	0.76	12.00	14.50		
	ENH4X36*17**	MV08B15**B*	TDR&TXV	29,200	0.76	12.00	14.50		
	ENH4X36*17**	MV12F19**B*	TDR&TXV	29,200	0.76	12.00	14.50		
	ENH4X36*17**	NOMV106D12*	TDR&TXV	29,000	0.76	12.00	14.50		
	ENH4X36*17**	OLV098A12A	TDR&TXV	29,200	0.76	12.00	14.50		
	ENH4X36*17**	OLV112A16A	TDR&TXV	29,200	0.76	12.00	14.50		
	ENH4X36*17**	OMV098J12A	TDR&TXV	29,200	0.76	12.00	14.50		
	ENH4X36*17**	OMV112K14A	TDR&TXV	29,200	0.76	12.00	14.50		
	ENH4X36*17**	†	TXV	29,200	0.76	11.00		13.00	
	FEM4P30**A* + TXV	—	TDR	29,000	0.76	12.00			14.50
	FEM4P36**A* + TXV	—	TDR	29,400	0.76	12.00			14.50
	FS(M,U)4P30**A* + TXV	—	TDR	29,600	0.76	12.00			14.50
	FS(M,U)4P36**A* + TXV	—	TDR	29,600	0.76	11.50			14.00
	FVM4X24****	—	TDR&TXV	29,000	0.76	12.00	14.50		
	FVM4X36****	—	TDR&TXV	29,400	0.76	12.00	14.50		
	FVM4X48****	—	TDR&TXV	30,000	0.76	12.00	14.50		
	FXM4X30**A*	—	TDR&TXV	29,600	0.76	12.00	14.50		
	FXM4X36**A*	—	TDR&TXV	29,800	0.76	12.00	14.50		
	HC4A336AKA HC4A336AHA HC4A336ALA	†ED*4X42J**	†	TXV	34,000	0.76	11.00		13.00
ED*4X42L**		*8MV*1352422**	TDR&TXV	34,000	0.76	12.00	14.50		
EHD4X36A**		*8MV*0701412**	TDR&TXV	34,000	0.76	12.00	14.50		
EHD4X36A**		*8MV*0901716**	TDR&TXV	34,000	0.76	12.00	14.50		
EHD4X36A**		*8MV*1102120**	TDR&TXV	34,000	0.76	12.00	14.50		
EHD4X36A**		*8MV*1352422**	TDR&TXV	34,000	0.76	12.00	14.50		
EHD4X36A**		*8MX*0451408**	TDR&TXV	34,000	0.76	11.50	14.00		
EHD4X36A**		*8MX*0701716**	TDR&TXV	34,000	0.76	12.00	14.50		
EHD4X36A**		*8MX*0902116**	TDR&TXV	34,000	0.76	12.00	14.50		
EHD4X36A**		*8MX*1102120**	TDR&TXV	34,000	0.76	12.00	14.50		
EHD4X36A**		NOMV106D12*	TDR&TXV	34,000	0.76	12.00	14.50		
EHD4X36A**		NOMV156E19*	TDR&TXV	34,000	0.76	12.00	14.50		
EHD4X42A**		*8MV*0701412**	TDR&TXV	34,200	0.76	12.00	14.50		
EHD4X42A**		*8MV*0901716**	TDR&TXV	34,200	0.76	12.00	14.50		
EHD4X42A**		*8MV*1102120**	TDR&TXV	34,200	0.76	12.00	14.50		
EHD4X42A**		*8MV*1352422**	TDR&TXV	34,200	0.76	12.00	14.50		
EHD4X42A**		*8MX*0451408**	TDR&TXV	34,200	0.76	11.50	14.00		
EHD4X42A**		*8MX*0701716**	TDR&TXV	34,200	0.76	12.00	14.50		
EHD4X42A**		*8MX*0902116**	TDR&TXV	34,200	0.76	12.00	14.50		
EHD4X42A**		*8MX*1102120**	TDR&TXV	34,200	0.76	12.00	14.50		
EHD4X42A**		NOMV106D12*	TDR&TXV	34,200	0.76	12.00	14.50		
EHD4X42A**		NOMV156E19*	TDR&TXV	34,200	0.76	12.00	14.50		
EN(A,D)4X36*21**		*8MV*1102120**	TDR&TXV	33,800	0.76	12.00	14.50		
EN(A,D)4X36*21**		*8MX*0902116**	TDR&TXV	34,000	0.76	12.00	14.50		
EN(A,D)4X36*21**		*8MX*1102120**	TDR&TXV	34,000	0.76	12.00	14.50		
EN(A,D)4X36*21**		NOMV156E19*	TDR&TXV	33,600	0.76	12.00	14.50		
EN(A,D)4X36*21**		OLV112A16A	TDR&TXV	33,800	0.76	11.50	14.00		
EN(A,D)4X36*21**		†	TXV	34,000	0.76	11.00		13.00	
EN(A,D)4X37*17**		*8MV*0901716**	TDR&TXV	35,000	0.76	12.00	14.50		
EN(A,D)4X37*17**		*8MX*0701716**	TDR&TXV	35,000	0.76	12.00	14.50		
EN(A,D)4X37*17**		NOMV106D12*	TDR&TXV	34,800	0.76	12.00	14.50		
EN(A,D)4X37*17**		OLV098A12A	TDR&TXV	34,800	0.76	12.00	14.50		
EN(A,D)4X37*17**		OMV098J12A	TDR&TXV	35,000	0.76	12.00	14.50		
EN(A,D)4X37*17**		OMV112K14A	TDR&TXV	35,000	0.76	12.00	14.50		
EN(A,D)4X37*17**	†	TXV	35,000	0.76	11.00		13.00		
EN(A,D)4X43*24**	*8MV*1352422**	TDR&TXV	34,800	0.76	12.00	14.50			
EN(A,D)4X43*24**	*9MPV125	TDR&TXV	34,800	0.76	12.00	14.50			
EN(A,D)4X43*24**	*9MVX100	TDR&TXV	34,800	0.76	12.00	14.50			
EN(A,D)4X43*24**	MV20L24**B*	TDR&TXV	34,800	0.76	12.00	14.50			

2009 ENERGY STAR compliance for combinations with both: SEER 14.50 (3 phase = 14.00) or higher and EER 12.00 or higher.

† For coils not listed with a matching furnace or blower, coil rating applies with any indoor blower device.

- continued on next page -

COOLING PERFORMANCE FOR COMBINATION RATINGS (continued) Indoor Models

For complete ratings information, use the AHRI website directory search: www.AHRIdirectory.org.
 New ratings may be listed online before Specification Sheets are updated.

Outdoor Model	Indoor Model († tested combo)	Furnace Model	Factory Installed	Cooling 95° F (35° C)			SEER		
				BTU/hr	S/T	EER	Factory	w/ Field TDR	w/ Field TXV
HC4A336AKA HC4A336AHA HC4A336ALA (continued)	EN(A,D,W)4X36*17**	*8MV*0901716**	TDR&TXV	33,800	0.76	12.00	14.50		
	EN(A,D,W)4X36*17**	*8MX*0701716**	TDR&TXV	33,600	0.76	11.50	14.00		
	EN(A,D,W)4X36*17**	NOMV106D12*	TDR&TXV	33,400	0.76	11.50	14.00		
	EN(A,D,W)4X36*17**	OLV098A12A	TDR&TXV	33,600	0.76	11.50	13.50		
	EN(A,D,W)4X36*17**	OMV098J12A	TDR&TXV	33,600	0.76	11.50	13.50		
	EN(A,D,W)4X36*17**	OMV112K14A	TDR&TXV	33,800	0.76	11.50	14.00		
	EN(A,D,W)4X36*17**	†	TXV	34,000	0.76	11.00		13.00	
	EN(A,D,W)4X42*21**	*8MV*1102120**	TDR&TXV	34,200	0.76	12.00	14.50		
	EN(A,D,W)4X42*21**	*8MX*0902116**	TDR&TXV	34,200	0.76	12.00	14.50		
	EN(A,D,W)4X42*21**	*8MX*1102120**	TDR&TXV	34,200	0.76	12.00	14.50		
	EN(A,D,W)4X42*21**	NOMV156E19*	TDR&TXV	34,000	0.76	12.00	14.50		
	EN(A,D,W)4X42*21**	OLV112A16A	TDR&TXV	34,200	0.76	11.50	14.00		
	EN(A,D,W)4X42*21**	†	TXV	34,200	0.76	11.00		13.00	
	END4X42*17**	*8MV*0901716**	TDR&TXV	34,200	0.76	12.00	14.50		
	END4X42*17**	*8MX*0701716**	TDR&TXV	34,200	0.76	12.00	14.50		
	END4X42*17**	NOMV106D12*	TDR&TXV	34,200	0.76	12.00	14.50		
	END4X42*17**	OLV098A12A	TDR&TXV	34,200	0.76	11.50	14.00		
	END4X42*17**	OMV098J12A	TDR&TXV	34,200	0.76	11.50	14.00		
	END4X42*17**	OMV112K14A	TDR&TXV	34,200	0.76	12.00	14.50		
	END4X42*17**	†	TXV	34,200	0.76	11.00		13.00	
	ENH4X36*17**	*8MPV050	TDR&TXV	33,400	0.76	11.50	13.50		
	ENH4X36*17**	*8MPV075	TDR&TXV	33,800	0.76	11.50	14.00		
	ENH4X36*17**	*8MPV100	TDR&TXV	34,000	0.76	12.00	14.50		
	ENH4X36*17**	*8MPV125	TDR&TXV	34,000	0.76	12.00	14.50		
	ENH4X36*17**	*8MV*0701412**	TDR&TXV	33,600	0.76	11.50	14.00		
	ENH4X36*17**	*8MV*0901716**	TDR&TXV	33,800	0.76	12.00	14.50		
	ENH4X36*17**	*8MV*1102120**	TDR&TXV	33,800	0.76	12.00	14.50		
	ENH4X36*17**	*8MV*1352422**	TDR&TXV	33,800	0.76	12.00	14.50		
	ENH4X36*17**	*8MX*0451408**	TDR&TXV	33,600	0.76	11.50	13.50		
	ENH4X36*17**	*8MX*0701716**	TDR&TXV	33,600	0.76	11.50	14.00		
	ENH4X36*17**	*8MX*0902116**	TDR&TXV	33,800	0.76	12.00	14.50		
	ENH4X36*17**	*8MX*1102120**	TDR&TXV	34,000	0.76	12.00	14.50		
	ENH4X36*17**	*9MPV050	TDR&TXV	33,600	0.76	11.50	13.50		
	ENH4X36*17**	*9MPV075	TDR&TXV	33,600	0.76	11.50	13.50		
	ENH4X36*17**	*9MPV100	TDR&TXV	34,000	0.76	11.50	14.00		
	ENH4X36*17**	*9MPV125	TDR&TXV	34,000	0.76	12.00	14.50		
	ENH4X36*17**	*9MVX040	TDR&TXV	33,600	0.76	11.50	13.50		
	ENH4X36*17**	*9MVX060	TDR&TXV	33,800	0.76	11.50	14.00		
	EN(A,D)4X43*24**	†	TXV	34,800	0.76	11.00		13.00	
	ENH4X36*17**	*9MVX080	TDR&TXV	34,000	0.76	11.50	14.00		
ENH4X36*17**	*9MVX100	TDR&TXV	34,000	0.76	12.00	14.50			
ENH4X36*17**	MV08B15**B*	TDR&TXV	34,000	0.76	12.00	14.50			
ENH4X36*17**	MV12F19**B*	TDR&TXV	34,000	0.76	12.00	14.50			
ENH4X36*17**	MV16J22**B*	TDR&TXV	34,000	0.76	12.00	14.50			
ENH4X36*17**	MV20L24**B*	TDR&TXV	34,000	0.76	12.00	14.50			
ENH4X36*17**	NOMV106D12*	TDR&TXV	33,400	0.76	11.50	14.00			
ENH4X36*17**	NOMV156E19*	TDR&TXV	33,600	0.76	12.00	14.50			
ENH4X36*17**	OLV098A12A	TDR&TXV	33,600	0.76	11.50	14.00			
ENH4X36*17**	OLV112A16A	TDR&TXV	33,800	0.76	11.50	14.00			
ENH4X36*17**	OLV154F20A	TDR&TXV	34,000	0.76	12.00	14.50			
ENH4X36*17**	OMV098J12A	TDR&TXV	33,600	0.76	11.50	13.50			

2009 ENERGY STAR compliance for combinations with both: SEER 14.50 (3 phase = 14.00) or higher and EER 12.00 or higher.

† For coils not listed with a matching furnace or blower, coil rating applies with any indoor blower device.

- continued on next page -

COOLING PERFORMANCE FOR COMBINATION RATINGS (continued) Indoor Models

For complete ratings information, use the AHRI website directory search: www.AHRI.org.
New ratings may be listed online before Specification Sheets are updated.

Outdoor Model	Indoor Model († tested combo)	Furnace Model	Factory Installed	Cooling 95° F (35° C)			SEER		
				BTU/hr	S/T	EER	Factory	w/ Field TDR	w/ Field TXV
HC4A336AKA HC4A336AHA HC4A336ALA (continued)	ENH4X36*17**	OMV112K14A	TDR&TXV	33,800	0.76	11.50	14.00		
	ENH4X36*17**	†	TXV	34,000	0.76	11.00		13.00	
	ENH4X42*21**	*8MPV050	TDR&TXV	33,800	0.76	11.50	13.50		
	ENH4X42*21**	*8MPV075	TDR&TXV	34,200	0.76	12.00	14.50		
	ENH4X42*21**	*8MPV100	TDR&TXV	34,200	0.76	12.00	14.50		
	ENH4X42*21**	*8MV*0701412**	TDR&TXV	34,000	0.76	12.00	14.50		
	ENH4X42*21**	*8MV*0901716**	TDR&TXV	34,000	0.76	12.00	14.50		
	ENH4X42*21**	*8MV*1102120**	TDR&TXV	34,200	0.76	12.00	14.50		
	ENH4X42*21**	*8MV*1352422**	TDR&TXV	34,200	0.76	12.00	14.50		
	ENH4X42*21**	*8MX*0451408**	TDR&TXV	34,000	0.76	11.50	14.00		
	ENH4X42*21**	*8MX*0701716**	TDR&TXV	34,000	0.76	11.50	14.00		
	ENH4X42*21**	*8MX*0902116**	TDR&TXV	34,200	0.76	12.00	14.50		
	ENH4X42*21**	*8MX*1102120**	TDR&TXV	34,200	0.76	12.00	14.50		
	ENH4X42*21**	*9MPV050	TDR&TXV	34,000	0.76	11.50	13.50		
	ENH4X42*21**	*9MPV075	TDR&TXV	34,000	0.76	11.50	14.00		
	ENH4X42*21**	*9MPV100	TDR&TXV	34,200	0.76	12.00	14.50		
	ENH4X42*21**	*9MPV125	TDR&TXV	34,200	0.76	12.00	14.50		
	ENH4X42*21**	*9MVX040	TDR&TXV	34,000	0.76	11.50	13.50		
	ENH4X42*21**	*9MVX060	TDR&TXV	34,200	0.76	11.50	14.00		
	ENH4X42*21**	*9MVX080	TDR&TXV	34,200	0.76	12.00	14.50		
	ENH4X42*21**	*9MVX100	TDR&TXV	34,200	0.76	12.00	14.50		
	ENH4X42*21**	MV08B15**B*	TDR&TXV	34,200	0.76	12.00	14.50		
	ENH4X42*21**	MV12F19**B*	TDR&TXV	34,200	0.76	12.00	14.50		
	ENH4X42*21**	MV16J22**B*	TDR&TXV	34,200	0.76	12.00	14.50		
	ENH4X42*21**	MV20L24**B*	TDR&TXV	34,200	0.76	12.00	14.50		
	ENH4X42*21**	NOMV106D12*	TDR&TXV	33,800	0.76	12.00	14.50		
	ENH4X42*21**	NOMV156E19*	TDR&TXV	34,000	0.76	12.00	14.50		
	ENH4X42*21**	OLV098A12A	TDR&TXV	34,000	0.76	11.50	14.00		
	ENH4X42*21**	OLV112A16A	TDR&TXV	34,200	0.76	11.50	14.00		
	ENH4X42*21**	OLV154F20A	TDR&TXV	34,200	0.76	12.00	14.50		
	ENH4X42*21**	OMV098J12A	TDR&TXV	34,000	0.76	11.50	14.00		
	ENH4X42*21**	OMV112K14A	TDR&TXV	34,200	0.76	12.00	14.50		
	ENH4X42*21**	†	TXV	34,200	0.76	11.00		13.00	
	ENH4X43*21**	*8MPV050	TDR&TXV	34,800	0.76	11.50	14.00		
	ENH4X43*21**	*8MPV075	TDR&TXV	34,800	0.76	12.00	14.50		
	ENH4X43*21**	*8MPV100	TDR&TXV	34,800	0.76	12.00	14.50		
	ENH4X43*21**	*8MPV125	TDR&TXV	34,800	0.76	12.00	14.50		
	ENH4X43*21**	*8MV*0701412**	TDR&TXV	34,800	0.76	12.00	14.50		
	ENH4X43*21**	*8MV*0901716**	TDR&TXV	34,800	0.76	12.00	14.50		
	ENH4X43*21**	*8MV*1102120**	TDR&TXV	34,800	0.76	12.00	14.50		
	ENH4X43*21**	*8MV*1352422**	TDR&TXV	34,800	0.76	12.00	14.50		
	ENH4X43*21**	*8MPV125	TDR&TXV	34,200	0.76	12.00	14.50		
ENH4X43*21**	*8MX*0451408**	TDR&TXV	34,800	0.76	11.50	14.00			
ENH4X43*21**	*8MX*0701716**	TDR&TXV	34,800	0.76	12.00	14.50			
ENH4X43*21**	*8MX*0902116**	TDR&TXV	34,800	0.76	12.00	14.50			
ENH4X43*21**	*8MX*1102120**	TDR&TXV	34,800	0.76	12.00	14.50			
ENH4X43*21**	*9MPV050	TDR&TXV	34,800	0.76	11.50	14.00			
ENH4X43*21**	*9MPV075	TDR&TXV	34,800	0.76	12.00	14.50			
ENH4X43*21**	*9MPV100	TDR&TXV	34,800	0.76	12.00	14.50			
ENH4X43*21**	*9MPV125	TDR&TXV	34,800	0.76	12.00	14.50			
ENH4X43*21**	*9MVX040	TDR&TXV	34,800	0.76	11.50	14.00			
ENH4X43*21**	*9MVX060	TDR&TXV	34,800	0.76	12.00	14.50			
ENH4X43*21**	*9MVX080	TDR&TXV	34,800	0.76	12.00	14.50			
ENH4X43*21**	*9MVX100	TDR&TXV	34,800	0.76	12.00	14.50			
ENH4X43*21**	MV08B15**B*	TDR&TXV	34,800	0.76	12.00	14.50			
ENH4X43*21**	MV12F19**B*	TDR&TXV	34,800	0.76	12.00	14.50			

2009 ENERGY STAR compliance for combinations with both: SEER 14.50 (3 phase = 14.00) or higher and EER 12.00 or higher.

† For coils not listed with a matching furnace or blower, coil rating applies with any indoor blower device.

- continued on next page -

COOLING PERFORMANCE FOR COMBINATION RATINGS (continued) Indoor Models

For complete ratings information, use the AHRI website directory search: www.AHRI.org.
New ratings may be listed online before Specification Sheets are updated.

Outdoor Model	Indoor Model († tested combo)	Furnace Model	Factory Installed	Cooling 95° F (35° C)			SEER		
				BTU/hr	S/T	EER	Factory	w/ Field TDR	w/ Field TXV
HC4A336AKA HC4A336AHA HC4A336ALA (continued)	ENH4X43*21**	MV16J22**B*	TDR&TXV	34,800	0.76	12.00	14.50		
	ENH4X43*21**	MV20L24**B*	TDR&TXV	34,800	0.76	12.00	14.50		
	ENH4X43*21**	NOMV106D12*	TDR&TXV	34,800	0.76	12.00	14.50		
	ENH4X43*21**	NOMV156E19*	TDR&TXV	34,800	0.76	12.00	14.50		
	ENH4X43*21**	OLV098A12A	TDR&TXV	34,800	0.76	12.00	14.50		
	ENH4X43*21**	OLV112A16A	TDR&TXV	34,800	0.76	12.00	14.50		
	ENH4X43*21**	OLV154F20A	TDR&TXV	34,800	0.76	12.00	14.50		
	ENH4X43*21**	OMV098J12A	TDR&TXV	34,800	0.76	12.00	14.50		
	ENH4X43*21**	OMV112K14A	TDR&TXV	34,800	0.76	12.00	14.50		
	ENH4X43*21**	†	TXV	34,800	0.76	11.00		13.00	
	FEM4P36**A* + TXV	—	TDR	34,000	0.76	11.50			13.50
	FEM4P42**A* + TXV	—	TDR	34,800	0.76	12.00			14.50
	FS(M,U)4P36**A* + TXV	—	TDR	34,000	0.76	11.50			13.50
	FS(M,U)4P42**A* + TXV	—	TDR	34,600	0.76	11.50			14.00
	FVM4X24***	—	TDR&TXV	33,000	0.76	11.50	14.00		
	FVM4X36***	—	TDR&TXV	33,400	0.76	12.00	14.50		
	FVM4X48***	—	TDR&TXV	34,800	0.76	12.00	14.50		
	FVM4X60***	—	TDR&TXV	35,200	0.76	12.00	14.50		
	FXM4X36**A*	—	TDR&TXV	35,000	0.76	12.00	14.50		
	FXM4X42**A*	—	TDR&TXV	35,000	0.76	12.00	14.50		
HC4A348AKA HC4A348AHA HC4A348ALA	†ED*4X48J**	†	TXV	46,500	0.76	11.00		13.00	
	ED*4X48L**	*8MV*1352422**	TDR&TXV	46,000	0.76	12.00	14.00		
	ED*4X48L**	*8MX*1352420**	TDR&TXV	46,000	0.76	12.00	14.00		
	ED*4X60L**	*8MV*1352422**	TDR&TXV	46,500	0.76	12.00	14.50		
	ED*4X60L**	*8MX*1352420**	TDR&TXV	46,500	0.76	12.00	14.50		
	EHD4X48A**	*8MV*0901716**	TDR&TXV	46,000	0.76	11.50	14.00		
	EHD4X48A**	*8MV*1102120**	TDR&TXV	46,500	0.76	12.00	14.50		
	EHD4X48A**	*8MV*1352422**	TDR&TXV	46,500	0.76	12.00	14.50		
	EHD4X48A**	*8MX*0701716**	TDR&TXV	46,000	0.76	11.00	13.00		
	EHD4X48A**	*8MX*0902116**	TDR&TXV	46,500	0.76	12.00	14.50		
	EHD4X48A**	*8MX*1102120**	TDR&TXV	46,500	0.76	12.00	14.50		
	EHD4X48A**	*8MX*1352420**	TDR&TXV	46,500	0.76	12.00	14.50		
	EHD4X48A**	NOMV156E19*	TDR&TXV	46,000	0.76	11.50	14.00		
	EHD4X60A**	*8MV*0901716**	TDR&TXV	47,000	0.76	12.00	14.50		
	EHD4X60A**	*8MV*1102120**	TDR&TXV	47,000	0.76	12.00	14.50		
	EHD4X60A**	*8MV*1352422**	TDR&TXV	47,000	0.76	12.00	14.50		
	EHD4X60A**	*8MX*0701716**	TDR&TXV	47,000	0.76	11.50	13.50		
	EHD4X60A**	*8MX*0902116**	TDR&TXV	47,000	0.76	12.00	14.50		
	EHD4X60A**	*8MX*1102120**	TDR&TXV	47,000	0.76	12.00	14.50		
	EHD4X60A**	*8MX*1352420**	TDR&TXV	47,000	0.76	12.00	14.50		
	EHD4X60A**	NOMV156E19*	TDR&TXV	47,000	0.76	12.00	14.50		
	EN(A,D)4X48*24**	*8MV*1352422**	TDR&TXV	46,000	0.76	12.00	14.50		
	EN(A,D)4X48*24**	*8MX*1352420**	TDR&TXV	46,000	0.76	12.00	14.50		
	EN(A,D)4X48*24**	*9MPV125	TDR&TXV	46,000	0.76	11.50	14.00		
	EN(A,D)4X48*24**	*9MVX100	TDR&TXV	46,000	0.76	11.50	14.00		
	EN(A,D)4X48*24**	MV20L24**B*	TDR&TXV	46,500	0.76	12.00	14.50		
	EN(A,D)4X48*24**	†	TXV	46,500	0.76	11.00		13.00	
	EN(A,D)4X61*24**	*8MV*1352422**	TDR&TXV	47,500	0.76	12.00	14.50		
	EN(A,D)4X61*24**	*8MX*1352420**	TDR&TXV	47,500	0.76	12.00	14.50		
	EN(A,D)4X61*24**	*9MPV125	TDR&TXV	47,500	0.76	12.00	14.50		
	EN(A,D)4X61*24**	*9MVX100	TDR&TXV	47,500	0.76	12.00	14.50		
	EN(A,D)4X61*24**	MV20L24**B*	TDR&TXV	47,500	0.76	12.00	14.50		
	EN(A,D)4X61*24**	†	TXV	47,500	0.76	11.00		13.00	
	EN(A,D,W)4X48*21**	*8MV*1102120**	TDR&TXV	46,000	0.76	12.00	14.50		
	EN(A,D,W)4X48*21**	*8MX*0902116**	TDR&TXV	46,000	0.76	11.50	14.00		

2009 ENERGY STAR compliance for combinations with both: SEER 14.50 (3 phase = 14.00) or higher and EER 12.00 or higher.

† For coils not listed with a matching furnace or blower, coil rating applies with any indoor blower device.

- continued on next page -

COOLING PERFORMANCE FOR COMBINATION RATINGS (continued) Indoor Models									
For complete ratings information, use the AHRI website directory search: www.AHRI.org .									
New ratings may be listed online before Specification Sheets are updated.									
Outdoor Model	Indoor Model († tested combo)	Furnace Model	Factory Installed	Cooling 95° F (35° C)			SEER		
				BTU/hr	S/T	EER	Factory	w/ Field TDR	w/ Field TXV
HC4A348AKA HC4A348AHA HC4A348ALA (continued)	EN(A,D,W)4X48*21**	*8MX*1102120**	TDR&TXV	46,000	0.76	12.00	14.50		
	EN(A,D,W)4X48*21**	NOMV156E19*	TDR&TXV	46,000	0.76	11.50	14.00		
	EN(A,D,W)4X48*21**	OLV112A16A	TDR&TXV	46,000	0.76	11.50	13.50		
	EN(A,D,W)4X48*21**	†	TXV	46,500	0.76	11.00		13.00	
	EN(A,D,W)4X60*24**	*8MV*1352422**	TDR&TXV	46,500	0.76	12.00	14.50		
	EN(A,D,W)4X60*24**	*8MX*1352420**	TDR&TXV	47,000	0.76	12.00	14.50		
	EN(A,D,W)4X60*24**	*9MPV125	TDR&TXV	47,000	0.76	12.00	14.50		
	EN(A,D,W)4X60*24**	*9MVX100	TDR&TXV	47,000	0.76	12.00	14.50		
	EN(A,D,W)4X60*24**	MV20L24**B*	TDR&TXV	47,000	0.76	12.00	14.50		
	EN(A,D,W)4X60*24**	†	TXV	47,000	0.76	11.00		13.00	
	ENH4X48*21**	*8MPV125	TDR&TXV	46,500	0.76	12.00	14.50		
	ENH4X48*21**	*8MV*0901716**	TDR&TXV	46,000	0.76	11.50	14.00		
	ENH4X48*21**	*8MV*1102120**	TDR&TXV	46,000	0.76	12.00	14.50		
	ENH4X48*21**	*8MV*1352422**	TDR&TXV	46,000	0.76	12.00	14.50		
	ENH4X48*21**	*8MX*0701716**	TDR&TXV	45,500	0.76	11.00	13.00		
	ENH4X48*21**	*8MX*0902116**	TDR&TXV	46,000	0.76	11.50	14.00		
	ENH4X48*21**	*8MX*1102120**	TDR&TXV	46,000	0.76	12.00	14.50		
	ENH4X48*21**	*8MX*1352420**	TDR&TXV	46,000	0.76	12.00	14.50		
	ENH4X48*21**	*9MPV100	TDR&TXV	46,000	0.76	11.50	14.00		
	ENH4X48*21**	*9MPV125	TDR&TXV	46,000	0.76	11.50	14.00		
	ENH4X48*21**	*9MVX080	TDR&TXV	46,500	0.76	11.50	14.00		
	ENH4X48*21**	*9MVX100	TDR&TXV	46,000	0.76	11.50	14.00		
	ENH4X48*21**	MV16J22**B*	TDR&TXV	46,500	0.76	12.00	14.50		
	ENH4X48*21**	MV20L24**B*	TDR&TXV	46,500	0.76	12.00	14.50		
	ENH4X48*21**	NOMV156E19*	TDR&TXV	46,000	0.76	11.50	14.00		
	ENH4X48*21**	OLV112A16A	TDR&TXV	46,000	0.76	11.50	13.50		
	ENH4X48*21**	OLV154F20A	TDR&TXV	46,500	0.76	11.50	14.00		
	ENH4X48*21**	†	TXV	46,500	0.76	11.00		13.00	
	ENH4X60*24**	*8MPV100	TDR&TXV	47,000	0.76	12.00	14.50		
	ENH4X60*24**	*8MPV125	TDR&TXV	47,000	0.76	12.00	14.50		
	ENH4X60*24**	*8MV*0901716**	TDR&TXV	46,500	0.76	12.00	14.50		
	ENH4X60*24**	*8MV*1102120**	TDR&TXV	46,500	0.76	12.00	14.50		
	ENH4X60*24**	*8MV*1352422**	TDR&TXV	46,500	0.76	12.00	14.50		
	ENH4X48*21**	*8MPV100	TDR&TXV	46,500	0.76	11.50	14.00		
	ENH4X60*24**	*8MX*0701716**	TDR&TXV	46,500	0.76	11.50	13.50		
	ENH4X60*24**	*8MX*0902116**	TDR&TXV	47,000	0.76	12.00	14.50		
	ENH4X60*24**	*8MX*1102120**	TDR&TXV	47,000	0.76	12.00	14.50		
	ENH4X60*24**	*8MX*1352420**	TDR&TXV	47,000	0.76	12.00	14.50		
	ENH4X60*24**	*9MPV100	TDR&TXV	47,000	0.76	11.50	14.00		
	ENH4X60*24**	*9MPV125	TDR&TXV	47,000	0.76	12.00	14.50		
ENH4X60*24**	*9MVX080	TDR&TXV	47,000	0.76	11.50	14.00			
ENH4X60*24**	*9MVX100	TDR&TXV	47,000	0.76	12.00	14.50			
ENH4X60*24**	MV16J22**B*	TDR&TXV	47,000	0.76	12.00	14.50			
ENH4X60*24**	MV20L24**B*	TDR&TXV	47,000	0.76	12.00	14.50			
ENH4X60*24**	NOMV156E19*	TDR&TXV	46,500	0.76	12.00	14.50			
ENH4X60*24**	OLV112A16A	TDR&TXV	46,500	0.76	11.50	13.50			
ENH4X60*24**	OLV154F20A	TDR&TXV	47,000	0.76	11.50	14.00			
ENH4X60*24**	†	TXV	47,000	0.76	11.00		13.00		
ENH4X61*24**	*8MPV100	TDR&TXV	47,500	0.76	12.00	14.50			
ENH4X61*24**	*8MPV125	TDR&TXV	47,500	0.76	12.00	14.50			
ENH4X61*24**	*8MV*0901716**	TDR&TXV	46,500	0.76	12.00	14.50			
ENH4X61*24**	*8MV*1102120**	TDR&TXV	47,000	0.76	12.00	14.50			
ENH4X61*24**	*8MV*1352422**	TDR&TXV	47,000	0.76	12.00	14.50			
ENH4X61*24**	*8MX*0701716**	TDR&TXV	46,500	0.76	11.50	13.50			

2009 ENERGY STAR compliance for combinations with both: SEER 14.50 (3 phase = 14.00) or higher and EER 12.00 or higher.

† For coils not listed with a matching furnace or blower, coil rating applies with any indoor blower device.

- continued on next page -

COOLING PERFORMANCE FOR COMBINATION RATINGS (continued) Indoor Models

For complete ratings information, use the AHRI website directory search: www.AHRI.org.
New ratings may be listed online before Specification Sheets are updated.

Outdoor Model	Indoor Model († tested combo)	Furnace Model	Factory Installed	Cooling 95° F (35° C)			SEER		
				BTU/hr	S/T	EER	Factory	w/ Field TDR	w/ Field TXV
HC4A348AKA HC4A348AHA HC4A348ALA (continued)	ENH4X61*24**	*8MX*0902116**	TDR&TXV	47,000	0.76	12.00	14.50		
	ENH4X61*24**	*8MX*1102120**	TDR&TXV	47,000	0.76	12.00	14.50		
	ENH4X61*24**	*8MX*1352420**	TDR&TXV	47,000	0.76	12.00	14.50		
	ENH4X61*24**	*9MPV100	TDR&TXV	47,000	0.76	11.50	14.00		
	ENH4X61*24**	*9MPV125	TDR&TXV	47,000	0.76	12.00	14.50		
	ENH4X61*24**	*9MVX080	TDR&TXV	47,000	0.76	11.50	14.00		
	ENH4X61*24**	*9MVX100	TDR&TXV	47,000	0.76	12.00	14.50		
	ENH4X61*24**	MV16J22**B*	TDR&TXV	47,500	0.76	12.00	14.50		
	ENH4X61*24**	MV20L24**B*	TDR&TXV	47,500	0.76	12.00	14.50		
	ENH4X61*24**	NOMV156E19*	TDR&TXV	47,000	0.76	12.00	14.50		
	ENH4X61*24**	OLV112A16A	TDR&TXV	47,000	0.76	11.50	13.50		
	ENH4X61*24**	OLV154F20A	TDR&TXV	48,000	0.76	11.50	14.00		
	ENH4X61*24**	†	TXV	47,500	0.76	11.00		13.00	
	FEM4P48**A* + TXV	—	TDR	46,500	0.76	11.50			14.00
	FEM4X60**B*	—	TDR&TXV	47,000	0.76	12.00	14.50		
	FS(M,U)4P48**A* + TXV	—	TDR	47,000	0.76	11.50			14.00
	FS(M,U)4X60**A*	—	TDR&TXV	47,500	0.76	11.50	13.50		
	FVM4X48***	—	TDR&TXV	46,500	0.76	12.00	14.50		
	FVM4X60***	—	TDR&TXV	47,000	0.76	12.00	14.50		
	FXM4X48**A*	—	TDR&TXV	47,500	0.76	12.00	14.50		
FXM4X60**A*	—	TDR&TXV	48,000	0.76	12.00	14.50			
HC4A360AKA HC4A360AHA HC4A360ALA	‡ED*4X60L**	†	TXV	57,000	0.77	11.00		13.00	
	ED*4X60L**	*8MV*1352422**	TDR&TXV	57,000	0.77	11.00	13.20		
	ED*4X60L**	*8MX*1352420**	TDR&TXV	56,500	0.77	11.00	13.20		
	EHD4X60A**	*8MV*1102120**	TDR&TXV	57,000	0.77	11.00	13.00		
	EHD4X60A**	*8MV*1352422**	TDR&TXV	57,000	0.77	11.00	13.50		
	EHD4X60A**	*8MX*1102120**	TDR&TXV	57,000	0.77	11.00	13.50		
	EHD4X60A**	*8MX*1352420**	TDR&TXV	57,000	0.77	11.00	13.50		
	EN(A,D)4X61*24**	*8MV*1352422**	TDR&TXV	57,500	0.77	11.00	13.50		
	EN(A,D)4X61*24**	*8MX*1352420**	TDR&TXV	57,500	0.77	11.00	13.50		
	EN(A,D)4X61*24**	MV20L24**B*	TDR&TXV	57,500	0.77	11.50	13.50		
	EN(A,D)4X61*24**	†	TXV	57,500	0.77	11.00		13.00	
	EN(A,D,W)4X60*24**	*8MV*1352422**	TDR&TXV	57,000	0.77	11.00	13.00		
	EN(A,D,W)4X60*24**	*8MX*1352420**	TDR&TXV	56,500	0.77	11.00	13.00		
	EN(A,D,W)4X60*24**	MV20L24**B*	TDR&TXV	57,000	0.77	11.50	13.50		
	EN(A,D,W)4X60*24**	†	TXV	57,000	0.77	11.00		13.00	
	ENH4X60*24**	*8MPV125	TDR&TXV	57,000	0.77	11.00	13.00		
	ENH4X60*24**	*8MV*1102120**	TDR&TXV	56,500	0.77	11.00	13.00		
	ENH4X60*24**	*8MV*1352422**	TDR&TXV	57,000	0.77	11.00	13.50		
	ENH4X60*24**	*8MX*1102120**	TDR&TXV	57,000	0.77	11.00	13.50		
	ENH4X60*24**	*8MX*1352420**	TDR&TXV	56,500	0.77	11.00	13.00		
	ENH4X60*24**	MV16J22**B*	TDR&TXV	57,000	0.77	11.50	13.50		
	ENH4X60*24**	MV20L24**B*	TDR&TXV	57,000	0.77	11.50	13.50		
	ENH4X60*24**	†	TXV	57,000	0.77	11.00		13.00	
	ENH4X61*24**	*8MPV125	TDR&TXV	57,500	0.77	11.00	13.00		
	ENH4X61*24**	*8MV*1102120**	TDR&TXV	57,000	0.77	11.00	13.00		
	ENH4X61*24**	*8MV*1352422**	TDR&TXV	57,000	0.77	11.00	13.00		
	ENH4X61*24**	*8MX*1102120**	TDR&TXV	57,000	0.77	11.00	13.00		
	ENH4X61*24**	*8MX*1352420**	TDR&TXV	57,000	0.77	11.00	13.00		
	ENH4X61*24**	MV16J22**B*	TDR&TXV	57,500	0.77	11.50	13.50		
	ENH4X61*24**	MV20L24**B*	TDR&TXV	57,500	0.77	11.00	13.50		
	ENH4X61*24**	†	TXV	57,000	0.77	11.00		13.00	
	FEM4X60**B*	—	TDR&TXV	56,500	0.77	11.00	13.00		
FVM4X60***	—	TDR&TXV	57,000	0.77	11.00	13.50			
FXM4X60**A*	—	TDR&TXV	57,500	0.77	11.00	13.50			

2009 ENERGY STAR compliance for combinations with both: SEER 14.50 (3 phase = 14.00) or higher and EER 12.00 or higher.

† For coils not listed with a matching furnace or blower, coil rating applies with any indoor blower device.

GUIDE SPECIFICATIONS

GENERAL

System Description

Outdoor-mounted, air-cooled, split-system air conditioner unit suitable for ground or rooftop installation. Unit consists of a hermetic compressor, an air-cooled coil, propeller-type condenser fan, and a control box. Unit will discharge supply air horizontally as shown on contract drawings. Unit will be used in a refrigeration circuit to match up to a packaged fan coil or coil unit.

Quality Assurance

- Unit will be rated in accordance with the latest edition of ARI Standard 210.
- Unit will be certified for capacity and efficiency, and listed in the latest ARI directory.
- Unit construction will comply with latest edition of ANSI/ASHRAE and with NEC.
- Unit will be constructed in accordance with UL standards and will carry the UL label of approval. Unit will have c-UL approval.
- Unit cabinet will be capable of withstanding Federal Test Method Standard No. 141 (Method 6061) 500-hr salt spray test.
- Air-cooled condenser coils will be leak tested and pressure tested
- Unit constructed in ISO9001 approved facility.

Delivery, Storage, and Handling

- Unit will be shipped as single package only and is stored and handled per unit manufacturer's recommendations.

Warranty (for inclusion by specifying engineer)

- U.S. and Canada only.

PRODUCTS

Equipment

- Factory assembled, single piece, air-cooled air conditioner unit. Contained within the unit enclosure is all factory wiring, piping, controls, compressor, refrigerant charge R-410A, and special features required prior to field start-up.

Unit Cabinet

- Unit cabinet will be constructed of galvanized steel, bonderized, and coated with a powder coat paint.

Fans

- Condenser fan will be direct-drive propeller type, discharging air horizontally.

AIR-COOLED, SPLIT-SYSTEM AIR CONDITIONER HC4A3 1-1/2 TO 5 NOMINAL TONS

- Condenser fan motors will be totally enclosed, 1-phase type with class B insulation and permanently lubricated bearings. Shafts will be corrosion resistant.
- Fan blades will be statically and dynamically balanced.
- Condenser fan openings will be equipped with coated steel wire safety guards.

Compressor

- Compressor will be hermetically sealed.
- Compressor will be mounted on rubber vibration isolators.

Condenser Coil

- Condenser coil will be air cooled.
- Coil will be constructed of aluminum fins mechanically bonded to copper tubes which are then cleaned, dehydrated, and sealed.

Refrigeration Components

- Refrigeration circuit components will include liquid-line front-seating shutoff valve with sweat connections, vapor-line front-seating shutoff valve with sweat connections, system charge of R-410A refrigerant, and compressor oil.
- Unit will be equipped with high-pressure switch and filter drier for R-410A refrigerant.

Operating Characteristics

- The capacity of the unit will meet or exceed _____ Btuh at a suction temperature of _____ °F. The power consumption at full load will not exceed _____ kW.
- Combination of the unit and the evaporator or fan coil unit will have a total net cooling capacity of _____ Btuh or greater at conditions of _____ CFM entering air temperature at the evaporator at _____ °F wet bulb and _____ °F dry bulb, and air entering the unit at _____ °F.
- The system will have a SEER of _____ Btuh/watt or greater at DOE conditions.

Electrical Requirements

- Nominal unit electrical characteristics will be _____ v, single phase, 60 hz. The unit will be capable of satisfactory operation within voltage limits of _____ v to _____ v.
- Nominal unit electrical characteristics will be _____ v, three phase, 60 hz. The unit will be capable of satisfactory operation within voltage limits of _____ v to _____ v.
- Unit electrical power will be single point connection.
- Control circuit will be 24v.

Special Features

- Refer to section of this literature identifying accessories and descriptions for specific features and available enhancements.

ACCESSORIES

Part Number	Description	Model — HC4A3											
		Size											
		18AK	24AK	30AK	36AK	36AH	36AL	48AK	48AH	48AL	60AK	60AH	60AL
AMF002OTA	OUTDOOR TSTAT KIT	—	—	—	—	—	—	—	—	—	—	—	—
NASA001TD	TIME DELAY KIT	X	X	X	X	X	X	X	X	X	X	X	X
EBAC05TXVX	TXV KIT, R-410A 2005-2009 R-22 TXV Fancoils (air handlers)	X	X	X	—	—	—	—	—	—	—	—	—
EBAC06TXVX		—	—	—	X	X	X	—	—	—	—	—	—
EBAC07TXVX		—	—	—	—	—	—	X	X	X	—	—	—
EBAC08TXVX		—	—	—	—	—	—	—	—	—	X	X	X
NAEA40501TX	TXV KIT, R-410A 2010 and later Piston Coils	X	X	X	—	—	—	—	—	—	—	—	—
NAEA40601TX		—	—	—	X	X	X	—	—	—	—	—	—
NAEA40701TX		—	—	—	—	—	—	X	X	X	—	—	—
NASA402LA	LOW AMBIENT KIT	X	X	X	X	X	X	X	X	X	X	X	X
NASA001FS	FRZ THERM KIT	X	X	X	X	X	X	X	X	X	X	X	X
NASA001WS	WINTER ST KIT	X	X	X	X	X	X	X	X	X	X	X	X
NASA001CH	CRANKCASE HEATER KIT	—	—	—	—	—	—	*	*	—	*	*	—
NASA002CH	CRANKCASE HEATER KIT	—	—	—	—	—	—	—	—	*	—	—	*
NASA003CH	CRANKCASE HEATER KIT	X	X	*	*	*	—	—	—	—	—	—	—
NASA004CH	CRANKCASE HEATER KIT	—	—	—	—	—	*	—	—	—	—	—	—
NASA001SJ	SOUND JACKET KIT	—	—	—	—	—	—	X	X	X	X	X	X
NASA002SJ	SOUND JACKET KIT	X	X	X	X	X	X	—	—	—	—	—	—
NASA001LS	SOL VALVE KIT	X	X	X	X	X	X	X	X	X	X	X	X
NASA001SC	PTC KIT	X	X	X	X	—	—	X	—	—	X	—	—
NASA003SC	HARD START KIT	X	X	X	X	—	—	X	—	—	X	—	—
NASA001AC	CYCLE PROTECTOR KIT	X	X	X	X	X	X	X	X	X	X	X	X
NASA00101WB	WIND BAFFLE KIT	X	—	—	—	—	—	—	—	—	—	—	—
NASA00201WB	WIND BAFFLE KIT	—	X	—	—	—	—	—	—	—	—	—	—
NASA00301WB	WIND BAFFLE KIT	—	—	X	X	X	X	—	—	—	—	—	—
NASA00401WB	WIND BAFFLE KIT	—	—	—	—	—	—	X	X	X	X	X	X
NASA00101SG	STACKING KIT	X	X	—	—	—	—	—	—	—	—	—	—
NASA00201SG	STACKING KIT	—	—	X	X	X	X	X	X	X	X	X	X
NASA00101WM	WALL MOUNT KIT	X	X	—	—	—	—	—	—	—	—	—	—
NASA00201WM	WALL MOUNT KIT	—	—	X	X	X	X	X	X	X	X	X	X

* Factory Installed